

Our associates will ensure the tool works properly before you leave the store. If you experience issues with the tool while completing your project, simply bring it back to the Tool Rental Center to get a replacement. If you purchase Damage Protection at the time of your rental, you are not responsible for repair costs for tools that break due to normal use.



BOMAG

Operating instructions Maintenance instructions

*This manual is
in accordance with
product liability laws
and safety regulations*

BW 900-2

S/N 901 800 00> S/N 861 800 02>

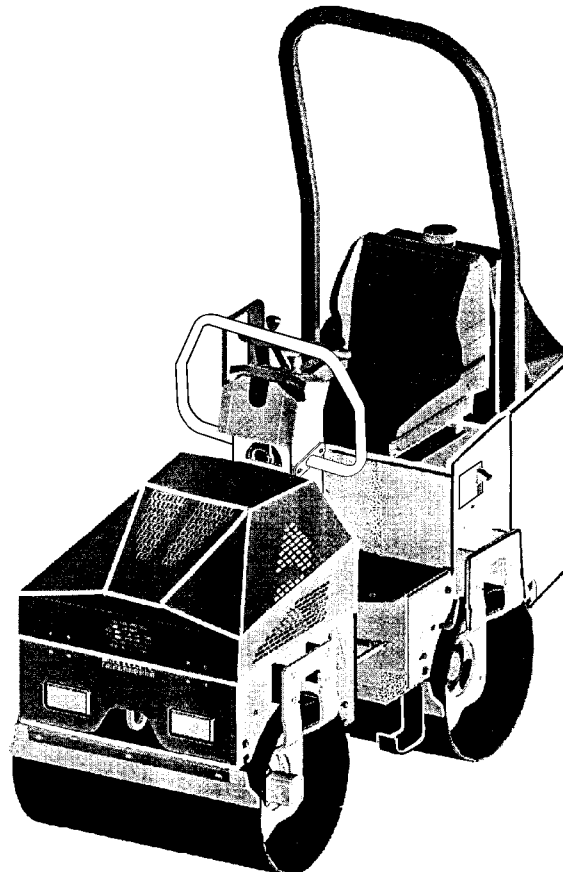

Tandem Vibratory Roller

If the machine is equipped with a battery :

CALIFORNIA

Proposition 65 Warning

Battery posts, terminals and related accessories contain lead and lead compounds, chemicals known to the State of California to cause cancer and birth defects or other reproductive harm.

Wash hands after handling.

If the machine is equipped with a diesel engine :

CALIFORNIA

Proposition 65 Warning

The engine exhaust and some of its constituents are known to the state of California to cause cancer, birth defects, and other reproductive harm.

BOMAG machines are products from the wide range of BOMAG compaction equipment.

BOMAG's vast experience in connection with state-of-the-art production and testing methods, such as lifetime tests of all important components and highest quality demands guarantees maximum reliability of your machine.

The instructions comprise:

- Safety regulations
- Operating instructions
- Maintenance instructions
- Troubleshooting

Using this manual will

- help you to become acquainted with the machine.
- avoid malfunctions caused by operating errors.

Compliance with the maintenance instructions will

- increase the reliability of the machine on the construction site,
- prolong the lifetime of the machine.
- reduce repair costs and downtime.

BOMAG will not assume liability for the function of the machine

- if it is handled in a way not complying with the usual modes of use,
- if it is used for purposes other than the ones it is intended for (see safety regulations).

No warranty claims can be lodged in case of damage resulting from

- operating errors,
- insufficient maintenance and
- wrong fuels and lubricants.

Please note!

This manual was written for operators and maintenance personnel on construction sites.

Always keep this manual close at hand, e.g. in the tool compartment of the machine or in a specially provided container. These operating and maintenance instructions are part of the machine.

You should only operate the machine if you are fully acquainted with the contents of these instructions.

Strictly observe the safety regulations.

Please observe also the guidelines of the Civil Engineering Liability Association "Safety Rules for the Operation of Road Rollers and Soil Compactors" and all relevant accident prevention regulations.

For your own personal safety you should only use original spare parts from BOMAG.

In the course of technical development we reserve the right for technical modifications without prior notification.

These operating and maintenance instructions are also available in other languages.

Furthermore, the spare parts catalogue is available from your BOMAG dealer against the serial number of your machine.

Your BOMAG dealer will also supply you with information about the correct use of our machines in soil and asphalt construction.

The above notes do not constitute an extension of the warranty and liability conditions specified in the general terms of business of BOMAG.

We wish you successful work with your BOMAG machine.

BOMAG GmbH & Co. OHG

Printed in Germany

Copyright by BOMAG

Foreword

Please fill in

.....

Machine type (Fig. 1)

.....

Serial No. (Fig. 1 and 2)

.....

Engine type (Fig. 3)

.....

Engine No. (Fig. 3)

i Note

Fill in the above listed data when receiving the machine.

Upon receipt of the machine our organization will instruct you about correct operation and maintenance.

Please observe strictly all safety regulations and notes on potential dangers!

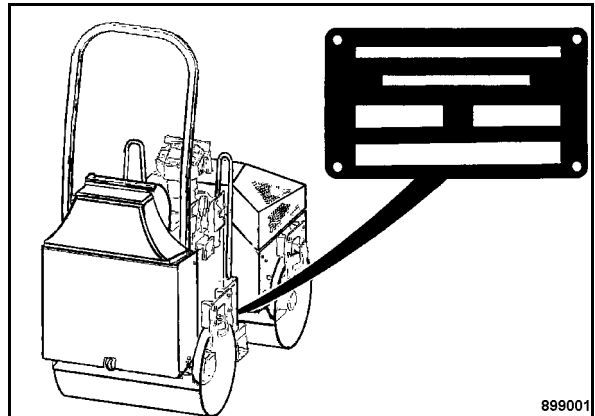

Fig. 1

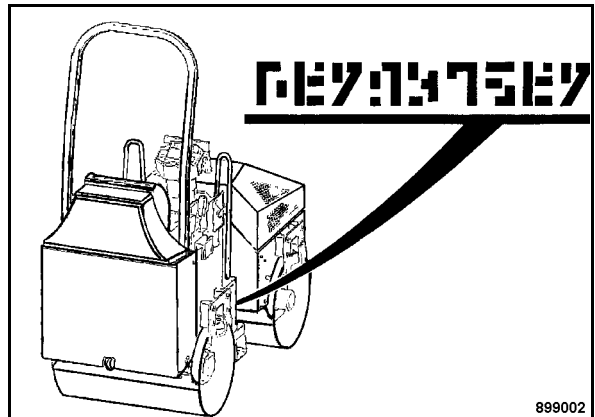

Fig. 2

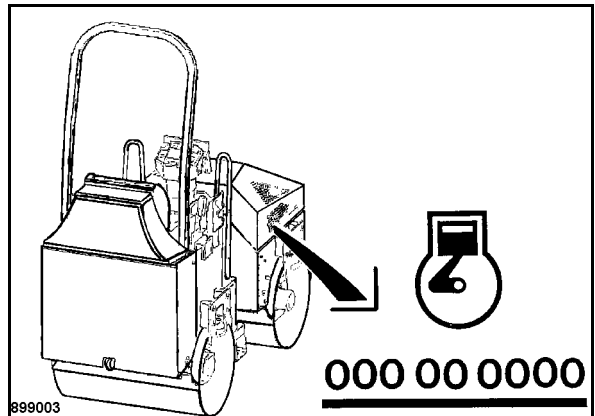

Fig. 3

Technical Data	7
Safety regulations	11
Indicators and Controls	19
3.1 General notes	22
3.2 Description of indicators and control elements	22
Operation	29
4.1 General notes	30
4.2 Tests before starting to operate	30
4.3 Starting the engine	31
4.4 Starting with jump leads	33
4.5 Driving the machine	33
4.6 Stopping the machine, operating the parking brake	34
4.7 Switching the vibration on or off	35
4.8 Switching the gravity sprinkler system on or off	36
4.9 Stopping the engine/machine	36
4.10 Adjusting the driver's seat	37
4.11 Towing	38
4.12 Loading and transport	39
Maintenance	41
5.1 General notes on maintenance	42
5.2 Fuels and lubricants	43
5.3 Fuels, lubricants and filling capacities	44
5.4 Running-in instructions	45
5.5 Maintenance table	46
5.6 Checking the engine oil level	47
5.7 Checking the fuel level	47
5.8 Checking the hydraulic oil level	48
5.9 Checking the hydraulic oil filter element	48
5.10 Check the water level	49
5.11 Cleaning the scrapers	49
5.12 Cleaning the cooling air intake opening	50
5.13 Greasing the articulated joint	51
5.14 Checking, cleaning the dry air filter	51
5.15 Cleaning, checking the spark plug	53
5.16 Changing the engine oil	53
5.17 Changing the engine oil filter	55
5.18 Changing the fuel pre-filter	56
5.19 Cleaning the sprinkler system	56
5.20 Checking the condition of the battery, greasing the poles	58
5.21 Checking, adjusting the valve clearance	59
5.22 Cleaning, changing the dry air filter	61

Table of Contents

	5.23 Changing the hydraulic oil	63
	5.24 Changing the hydraulic oil filter element	64
	5.25 Water sprinkler system, maintenance in the event of frost	65
	5.26 Tightening torques for screws with metric unified thread	65
	5.27 Engine conservation	66
Trouble shooting		67
	6.1 General notes	68
	6.2 Engine faults	69

1 Technical Data

Technical Data

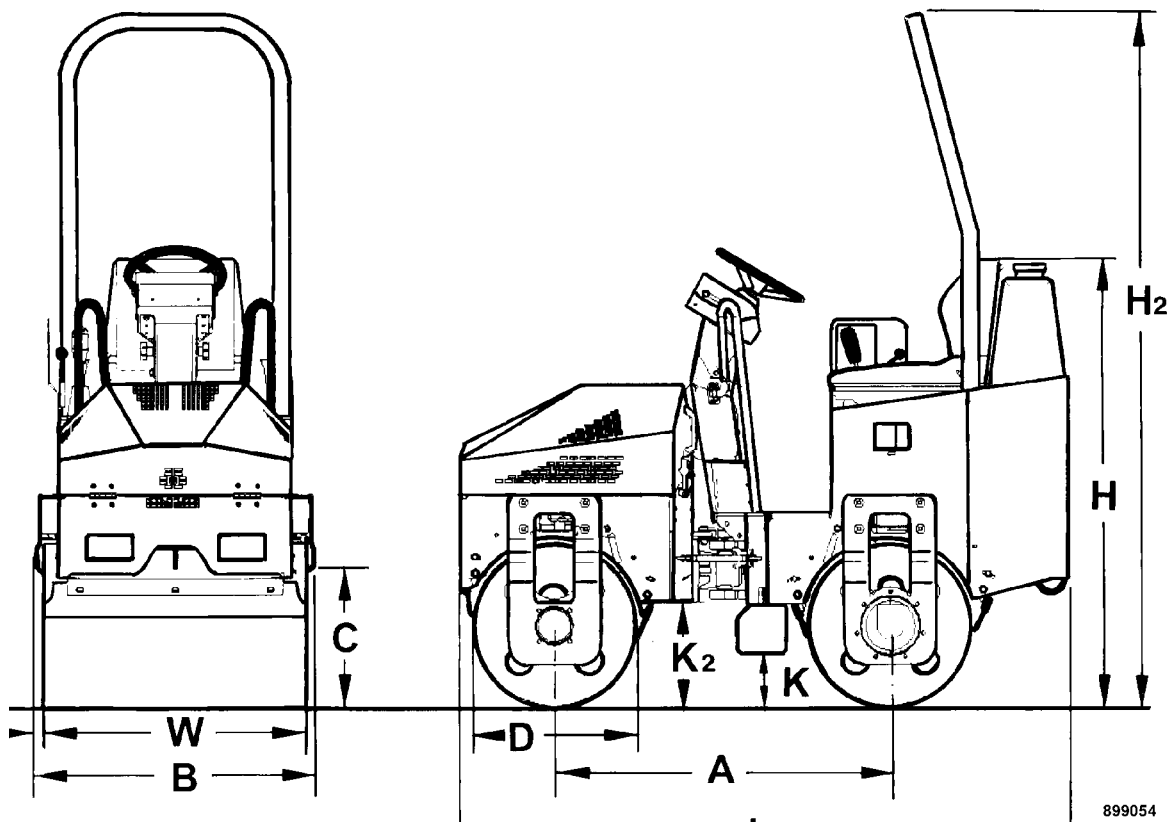

Fig. 4

Dimensions in mm	A	B	C	D	H	H2	K	K2	L	O1/O2	W
BW 900-2	1143	956	458	560	1620	2340	200	372	2080	28	900

*

BW 900-2

Weights

Operating weight CECE	kg	1326
Mean static linear load CECE	kg/cm	7,4

Dimensions

Working width	mm	900
---------------	----	-----

Travel characteristics

Travel speed (1)	km/h	0 to 4
Travel speed (2)	km/h	0 to 7,5
Max. gradability without/with vibration (soil dependent)	%	40/30

*

BW 900-2

Drive

Engine manufacturer/type		Honda GX 620
Cooling		Air
Number of cylinders		2
Rated power ISO 9249	kW (PS)	14,9 (20,3)
Rated speed	1 rpm	3000
Battery	V/AH	12/..
Drive system		hydrostatic
Driven axles		front + rear

Brakes

Service brake		hydrostatic
Parking brake		hydro.-mechanical

Steering

Type of steering		Oscill.-articul.
Steering operation		hydrostatic
Steering/oscillation angle	Degree	30/6

Vibration system

Vibrating drum		front
Drive system		hydrostatic
Frequency	Hz	65
Amplitude	mm	0,5
Centrifugal force	kN	13,5

Water sprinkler system

Type of sprinkling		Gravity feed
--------------------	--	--------------

Filling capacities

Fuel, unleaded standard grade gasoline	l	34
Water	l	189
Hydraulic oil	l	15

* The right for technical modifications remains reserved

2 Safety regulations

General

This BOMAG machine is built in accordance with the latest technical standard and the valid technical rules and regulations. There is, however, a risk of danger for persons and property if:

- the machine is used for purposes other than those it is intended for
- the machine is operated by untrained personnel
- the machine is modified or converted in an unprofessional way
- the applicable safety regulations are not observed.

Each person involved in operation, maintenance and repair of the machine must therefore read and apply these safety regulations. This should be confirmed by obtaining the signatures of the customer, if necessary.

Furthermore the following regulations and instructions are obviously also valid:

- applicable accident prevention instructions
- generally acknowledged safety and road traffic regulations
- country specific safety regulations. It is the duty of the operator to know and observe these regulations. This applies also for local regulations and the regulations for various types of manual work. If the recommendations in this manual differ from the regulations valid in your country, you must strictly observe the regulations in your country.

Intended use

This machine must only be used for:

- compaction of bituminous material, e.g. road surface layers
- light compaction work in earth construction (road sub-bases)
- You should only operate the unit with fully functional safety equipment.
- Have the machine inspected by an expert once every year.

Unintended use

Dangers may, however, arise from the machine if it is used by untrained personnel in an unprofessional way or if it is used for purposes other than those mentioned in these instructions.

Do not work with vibration on hard concrete, on a cured concrete layer or heavily frozen ground.

Starting and operation of the machine in an explosive environment is prohibited.

Who is allowed to work with the machine?

The machine must only be operated by trained and authorized persons which are at least 18 years of age. The responsibilities for the operation of the machine must be clearly specified and complied with.

Persons under the influence of alcohol, medication or drugs must not operate, service or repair the machine.

Maintenance and repair tasks require specific knowledge and must therefore only be carried out by trained and qualified personnel.

Conversions and alterations to the machine

Unauthorized conversions to the machine are prohibited for safety reasons.

Original parts and accessories have been specially designed for this machine. We wish to make expressly clear that we have not tested or authorized any original parts or special equipment not supplied by us. The installation and/or use of such products can impair the active and/or passive driving safety. The manufacturer expressly excludes any liability for damage resulting from the use of non-original parts or accessories.

Safety notes in the operating and maintenance instructions:

Danger

Sections marked like this point out possible dangers for persons.

Caution

Sections marked like this point out possible dangers for the machine or for parts of the machine.

Note

Sections marked like this provide technical information concerning the optimal economical use of the machine.

Environment

Sections marked like this highlight activities for the safe and environmental disposal of fuels and lubricants as well as replaced parts.

Observe all environment protection regulations.

Information and safety stickers/decals on the machine

Keep stickers/decals complete (see spare parts catalogue) and fully legible and observe their meaning.

Replace damaged or illegible stickers/decals immediately.

Loading the machine

Always check the fastening of the central lifting hook before attempting to lift the machine.

Use only strong and stable loading ramps. The ramp inclination must not exceed the gradability of the machine.

Secure the machine against turning over or slipping off.

Secure the machine on the transport vehicle against rolling, sliding and tipping over.

Persons are highly endangered if

- they step or stand under loads being lifted
- they remain in the drive range of the machine during a demonstration or during loading.

The machine must not swing about when lifted off the ground.

Use only safe lifting gear of sufficient load bearing capacity.

Attach the lifting gear only to the specified lifting points.

Towing the machine

You should generally use a tow bar.

Max. towing speed 1 km/h (1.6 mph), max. towing distance 500 m (1640 ft.).

Before releasing the multi-disc brakes secure the machine properly against unintended rolling.

Checking the roll-over protection structure (ROPS)

The machine frame must not be distorted, bent or cracked in the area of the ROPS structure.

The ROPS structure must not show any rust, damage, hairline cracks or open fractures.

The ROPS must not rattle about when driving the machine. This would mean that the fastening screws are insufficiently fastened. All screwed connections must be tight and in accordance with the specifications (observe the tightening torques). Screws and nuts must not be damaged, distorted or deformed.

No additional parts must be welded or bolted on and no holes must be drilled without the permission of the dealer, since this may impair the strength of the structure.

Starting the machine

Before starting

Operation of the machine is only permitted when sitting in the operator's seat.

Use only machines which have been properly serviced at regular intervals.

Become acquainted with the equipment, the control elements, the working mode of the machine and the area you will be working in.

Use your personal protective outfit (hard hat, safety boots etc.).

Check before mounting the machine if:

- there are persons or obstructions beside or under the machine
- the machine is free of any oily and combustible material
- all handrails, steps and platforms are free of grease, oils, fuels, dirt, snow and ice
- the engine compartment hood is closed and locked

Safety regulations

To climb onto the machine use steps and handrails.

Check before starting, whether:

- the machine shows any obvious defects
- all protective devices are properly secured in their place
- steering, brakes, control elements, lighting and warning horn are in order
- the seat is correctly adjusted
- the mirrors (if available) are clean and correctly adjusted.

Do not start the machine if any gauges, control lights or controls are defective.

Do not take any loose objects with you or fasten them to the machine.

On machines with ROPS you should always wear your seat belt!

Starting

Start and operate the machine only from the operator's seat

For starting set all control levers to "neutral position".

Do not use any starting aids such as Start Pilot or ether.

After starting check all gauges.

Starting with jump leads

Connect plus with plus and minus with minus (ground cable) - always connect the ground cable last and disconnect it first! Wrong connections may cause severe damage in the electric system.

Never start the engine by bridging the electrical connections on the starter, because the machine would probably start to move immediately.

Starting in closed rooms

Exhaust gases are toxic! Always ensure an adequate supply of fresh air when starting in closed rooms!

Driving the machine

Persons in the endangered area

Before starting or resuming work and especially when reversing, check that there are not any persons or obstructions in the endangered area.

If necessary give warning signals. Stop work immediately if persons remain in the danger area despite the warning.

Do not step or stand in the articulation area of the machine when the engine is running. Risk of squashing!

Driving

In events of an emergency operate the emergency stop switch immediately. Do not use the emergency stop switch as a service brake.

Restart the machine only after the danger, that has caused the actuation of the emergency stop, has been eliminated.

If the machine has come in contact with high-voltage power lines:

- do not leave the operator's stand
- warn others from coming too close to the machine or touching it
- if possible drive the machine out of the danger zone
- have the power shut off

Operate the machine only from the operator's seat.

Do not adjust the seat while driving.

Do not climb onto or off the machine while driving.

Change the travel direction only while the machine is standing.

Do not use the machine to transport persons.

Stop the machine if you notice unusual noises or the development of smoke. Investigate the cause and have the fault corrected.

Keep a sufficient distance to excavations and embankments and make sure that your work does not impair the stability of the machine.

Do not work with vibration on hard concrete, on a cured bitumen surface or heavily frozen ground.

When passing under flyovers, bridges, tunnels, electric power lines etc. keep a sufficient distance.

Driving on slopes and gradients

Do not drive up and down gradients, which exceed the max. gradability of the machine.

Always drive extremely carefully on slopes and always straight up and down the slope. Change to the lower speed range before approaching the slope.

Wet and loose soils reduce the ground adhesion of the machine on gradients and slopes. Higher risk of accident!

Behaviour in traffic

Match the speed of the machine to the working conditions.

Always allow loaded transport vehicles to pass.

Switch the lights on when the visibility is poor.

Keep clear of edges and embankments.

Check the effect of vibration

When compacting with vibration check the effect of the vibration on nearby buildings and underground supply lines (gas, water, sewage, electric power supply), stop vibratory compaction if necessary.

Do not activate the vibration on hard (frozen, concrete) ground. Risk of bearing damage!

Parking the machine

Park the machine on level and firm ground.

Before leaving the machine:

- return the travel lever to neutral position
- apply the parking brake
- shut the engine down and pull the ignition key out
- secure the machine against unauthorized use.

Do not jump off the machine, use access steps and hand rails.

Always secure parked machines, which could be in the way, with appropriate measures.

Parking on slopes and gradients

Secure the machine against rolling, place metal chocks in front of and behind the drums.

Filling the fuel tank

Do not inhale any fuel fumes.

Refuel only with the engine stopped.

Do not refuel in closed rooms.

No open fire, do not smoke.

Do not spill any fuel. Catch running out fuel, do not let it seep into the ground.

Wipe off spilled fuel. Keep dirt and water away from fuel.

Leaking fuel tanks can cause explosion. Ensure tight fit of the fuel tank lid, if necessary replace immediately.

Fire protection measures

Become acquainted with the location and the handling of fire extinguishers. Observe all possibilities for fire alarm and fire fighting.

Maintenance work

Comply with the maintenance work described in the operating and maintenance instructions, including the information concerning the replacement of parts.

Maintenance work must only be performed by qualified and authorized persons.

For overhead maintenance and assembly work use the access steps and working platforms provided or other secure means. Do not use machine parts as access steps.

Keep unauthorized persons away from the machine.

Do not perform maintenance work while the machine is driving or the engine is running.

Park the machine on horizontal, level and firm ground.

Pull the key out of the ignition switch.

Lock the articulated joint with the articulation lock.

Working on hydraulic lines

Always relieve the hydraulic pressures before working on hydraulic lines. Hydraulic oil escaping under pressure can penetrate the skin and cause severe injury. When being injured by hydraulic oil consult a medical doctor immediately, as otherwise this may cause severe infections.

Do not step in front of or behind the drums/wheels when performing adjustment work in the hydraulic system.

Do not change the setting of high pressure relief valves.

Drain hydraulic oil at operating temperature - danger of scalding!

Catch hydraulic oil and dispose of environmentally.

Always catch and dispose of biodegradable hydraulic oils separately.

Safety regulations

Do not start the engine after draining the hydraulic oil.

After finishing work (with the system still depressurized!) check all connections and fittings for leaks.

Changing hydraulic hoses

Hydraulic hoses must be inspected visually at regular intervals.

Hydraulic hoses must be immediately replaced if:

- the outer layer is damaged down to the inlay (e.g. chafing, cuts, cracks)
- the outer layer is brittle (formation of cracks in the hose material)
- the hose shows deformations in pressurized and depressurized condition, which do not comply with the genuine shape of the hydraulic hose
- the hose shows deformations in bends, e.g. squeezing, buckling, layer separation, formation of blisters
- leakages.
- installation faults.
- separation of the hydraulic hose from the fitting
- corrosion of the fitting impairing both function and strength.
- Do not mix up hoses by mistake.
- damage or deformation of fittings impairing the function and strength of the hose/hose connection. Only genuine replacement hydraulic hoses from BOMAG ensure that the correct hose type (pressure range) is used at the right location.

Working on the engine

Shut the engine down before opening the engine hood.

Drain the engine oil at operating temperature - danger of scalding!

Wipe off spilled oil, catch oil and dispose of environmentally.

Store used filters and other oil contaminated materials in a separate, specially marked container and dispose of environmentally.

Do not leave any tools or other objects, that could cause damage, in the engine compartment.

Working on electrical equipment

Before starting to work on electric parts of the machine disconnect the battery and cover it with insulating material.

Do not use fuses with higher ampere ratings and do not repair fuses with a piece of wire. Fire hazard!

Always disconnect the battery before starting welding work on the machine.

Working on the battery

When working on the battery do not smoke, do not use open fire!

Do not let acid come in contact with hands or clothes! When injured by acid flush off with clear water and seek medical advice.

Metal objects (e.g. tools, rings, watch straps) must not come in contact with the battery poles - danger of short circuit and burning!

When recharging maintenance-free batteries remove all plugs, to avoid the accumulation of explosive gases.

Observe the applicable instructions when starting with an auxiliary battery.

Dispose of old batteries environmentally.

Switch off the charging current before removing the charging clamps.

Ensure sufficient ventilation, especially if the battery is to be charged in a closed room.

Working on the fuel system

Do not inhale any fuel fumes.

No open fire, do not smoke, do not spill any fuel.

Catch fuel running out, do not let it seep into the ground and dispose of environmentally.

Cleaning work

Do not clean the machine while the engine is running.

Do not use gasoline or other inflammable substances for cleaning.

When cleaning with steam cleaning equipment do not subject electrical parts and insulation material to the direct jet of water, or cover it beforehand.

- Do not guide the water jet into the exhaust and into the air filter.

After maintenance work

After completion of maintenance work reinstall all guards and safety features.

Repair

Attach a warning tag to the steering wheel if the machine is defective.

Repairs must only be performed by qualified persons who have been instructed for this purpose. Use our repair instructions.

Exhaust gases are highly dangerous! Always ensure an adequate supply of fresh air when starting in closed rooms!

Test

Depending on the type of application and the operating conditions vibratory equipment has to be examined by a specialist whenever required, but at least once every year.



3 Indicators and Controls

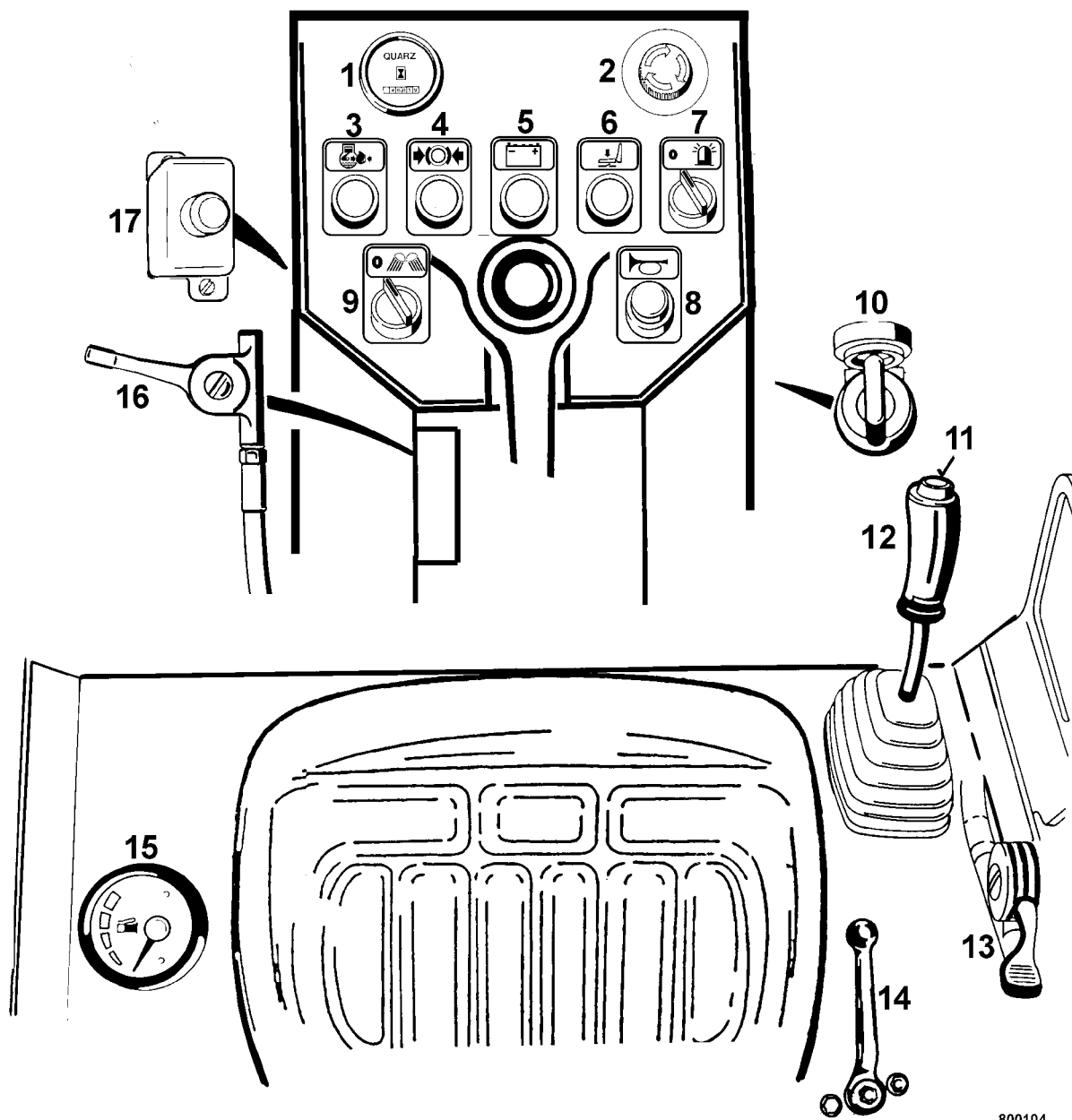

800104

Fig. 5

- 1 Operating hour meter
 - 2 Emergency stop push button
 - 3 Engine oil pressure warning light
 - 4 Parking brake warning light
 - 5 Charge control light
 - 6 Warning light for seat contact switch*
 - 7 Rotary switch for flashing beacon
 - 8 Rotary switch for working lights
 - 9 Push button for warning horn
 - 10 Ignition switch
 - 11 Push button for vibration
 - 12 Travel lever
 - 13 Throttle lever
 - 14 Ball valve for water sprinkling system
 - 15 Fuel level gauge
 - 16 Choke lever
 - 17 Fuses
- * Optional equipment

3.1 General notes

Please read this section thoroughly before operating this machine if you are not yet conversant with the indicators and control elements. All functions are described in detail hereunder.

Paragraph 4 Operation contains only concise descriptions of the individual operating steps.

3.2 Description of indicators and control elements

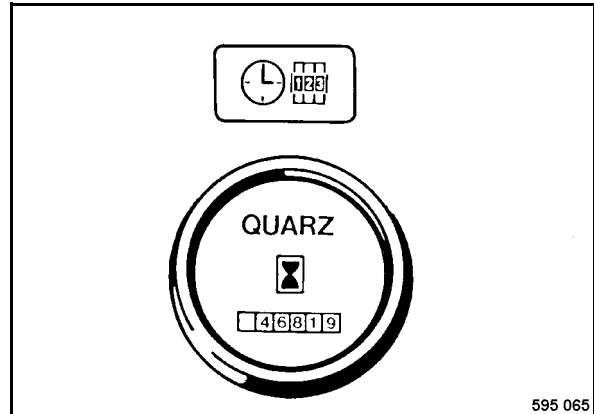

Fig. 6

No. 1 = Operating hour meter

counts the operating hours while the engine is running

All service work must be carried out according to the reading of the operating hour meter.

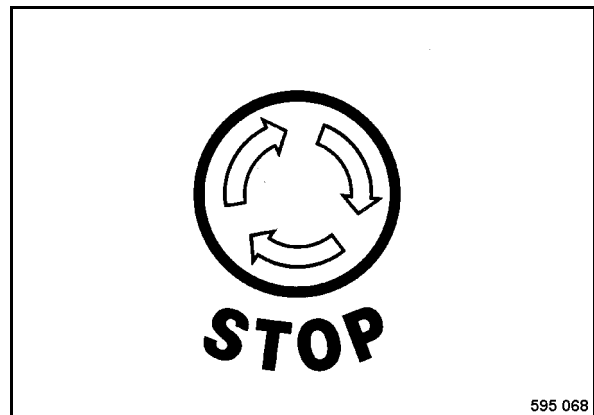

Fig. 7

No. 2 = Emergency stop switch Shuts the engine down and closes the brake.

▲ Danger

Danger of accident!

Actuate only in events of emergency during operation, do not use as service brake.

Restart the machine only after the danger that caused the actuation of the emergency stop switch has been eliminated.

- actuate = press the button completely down, it will automatically lock in fully pressed position.
- unlock = turn the button clockwise and release it.
- to drive = return the travel lever first to braking position, then start the engine and actuate the travel lever again.

For safety reasons the machine can only start to drive after returning the travel lever to braking position.

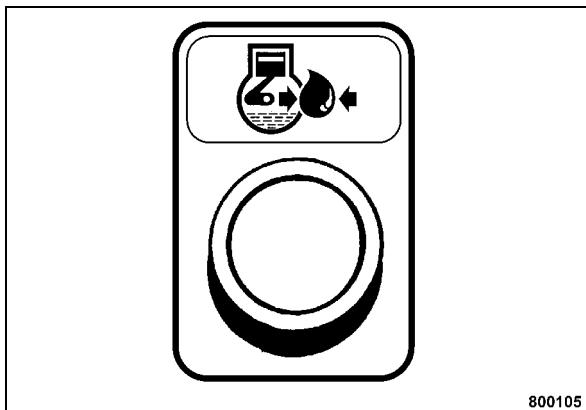

Fig. 8

No. 3 = Engine oil pressure warning light

- lights up = when switching the ignition on, in case of an engine oil pressure drop, shut the engine down immediately.
- goes out = after starting the engine.

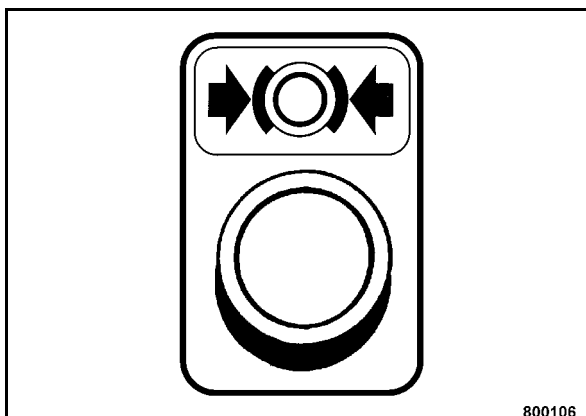

Fig. 9

No. 4 = Parking brake warning light

- lights = with the ignition switch in position "I" (test), with travel lever in neutral position, parking brake closed.
- goes out = when the travel lever is moved out of neutral position and the driver's seat is occupied*. Parking brake released.

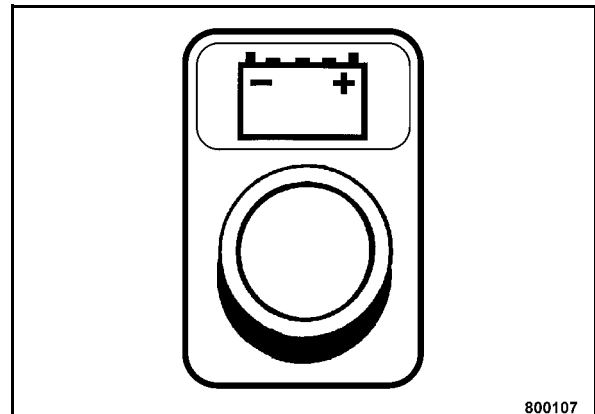

Fig. 10

No. 5 = Charge control light

- lights up = when switching the ignition on (test), in case of charging faults during operation.
- goes out = after starting the engine.

⚠ Caution

If the control light lights up while the engine is running, the battery is not being charged. Perform trouble shooting and have the fault corrected.

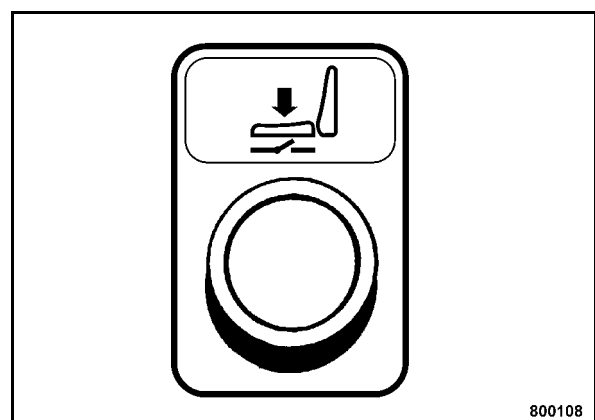

Fig. 11

No. 6 = Warning light for seat contact switch*

Indicators and Controls

- lights = with the ignition switch in position "I" (test), if the driver's seat is not occupied and the parking brake is closed, when actuating the travel lever while the driver's seat is not occupied.
- goes out = when the driver's seat is occupied and the travel lever is in brake position.

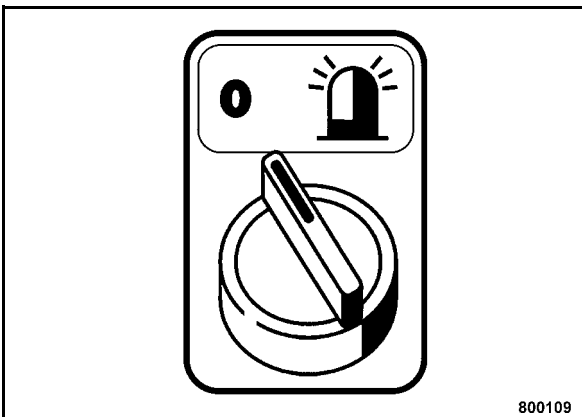

Fig. 12

No. 7 = Rotary switch for flashing beacon

Position "left" = Flashing beacon off

Position "right" = Flashing beacon on

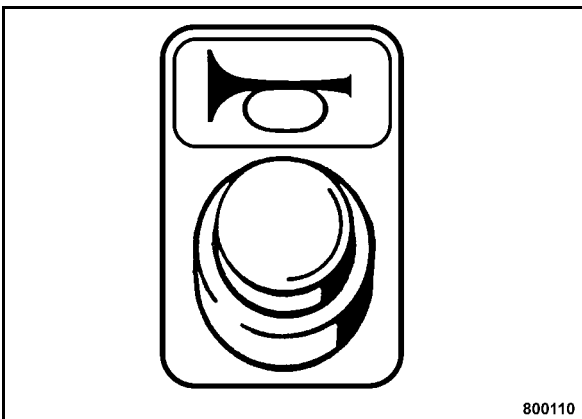

Fig. 13

No. 8 = Push button for warning horn

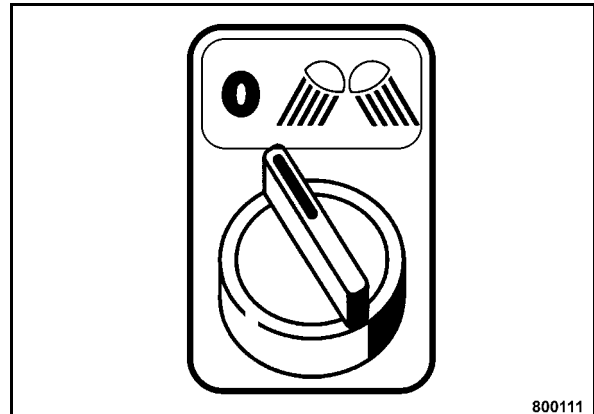

Fig. 14

No. 9 = Rotary switch, working lights

Working light front, rear

Position "left" = Light off

Position "right" = Working lights on, with ignition switch in position "I".

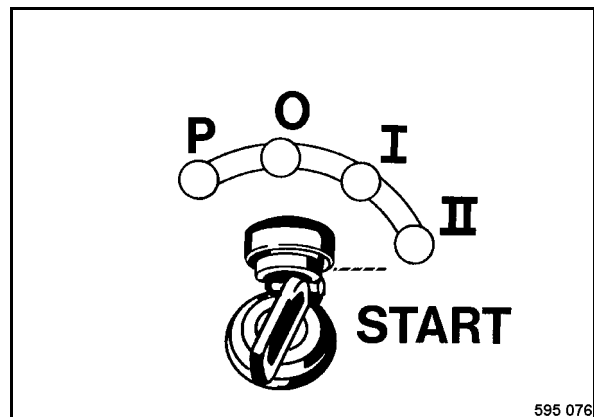

Fig. 15

No. 10 = Ignition switch

Position "P"/"O" = ignition off, the key can be pulled out, engine not running.

Position "I" = ignition on, the lights can be switched on.

i Note

The engine can only be started when the travel lever is in braking position and the emergency stop switch is unlocked.

The ignition switch is designed with a lock to prevent repetitive starting. For a new starting attempt the ignition key must first be turned back to position "O".

* Optional equipment

Position "II" = turn further against spring pressure, the engine starts, turn the ignition key back to position "I" once the engine has started

⚠ Caution

Run the engine warm for a short while before starting work. Do not allow the engine to run longer than 10 minutes with idle speed.

Do not shut the engine down all of the sudden from full speed, but let it idle for a while for temperature equalization.

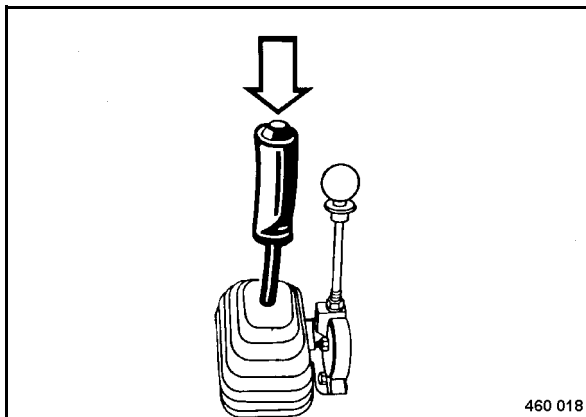

Fig. 16

No. 11 = Push button for vibration

depress = to switch the vibration on or off.

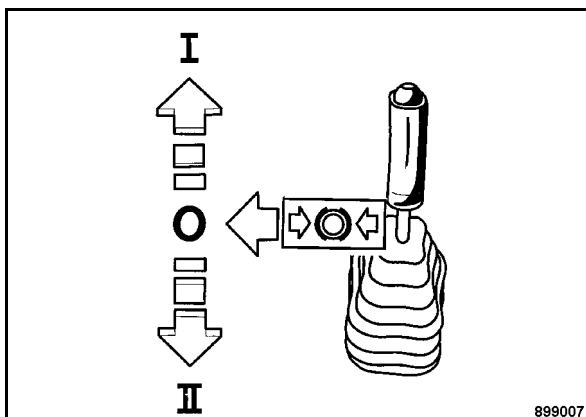

Fig. 17

No. 12 = Travel lever

press through position "0" to the right = parking brake applied, starting of engine possible.

Position "0" = service brake, the machine is automatically braked by the hydrostatic drive.

Position direction "I" = selection of travel speed forward according to the travel lever position.

Position direction "II" = selection of travel speed reverse according to the travel lever position.

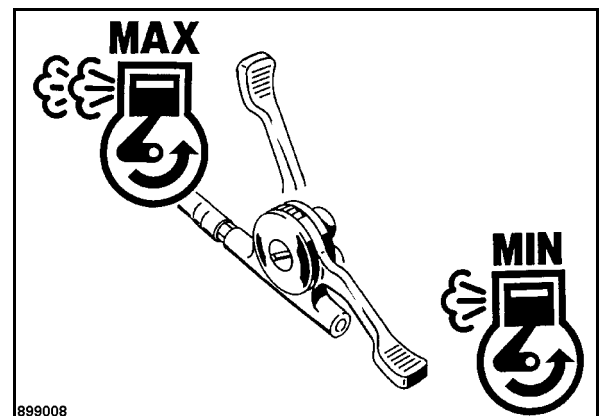

Fig. 18

No. 13 = Throttle lever

Position "MAX" = full speed position, operating position for driving and vibration.

Position "MIN" = idle speed position

⚠ Caution

Always drive and vibrate with max. engine speed! Control the travel speed only with the travel lever.

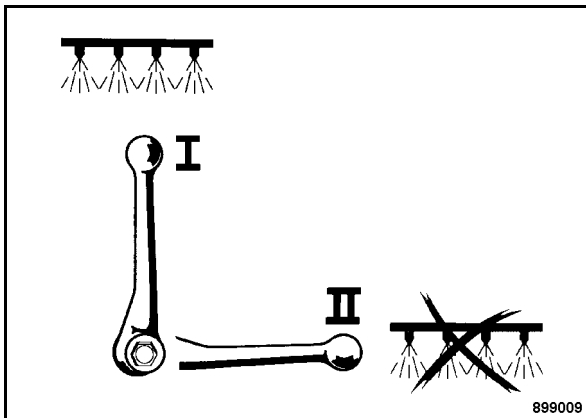

Fig. 19

No. 14 = Cock valve for sprinkler system

Position "I" = permanent sprinkling

Position "II" = sprinkling off

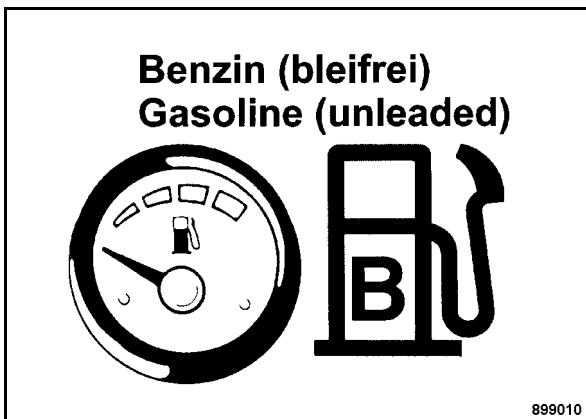

Fig. 20

No. 15 = Fuel level gauge

shows the fuel level in the fuel tank.

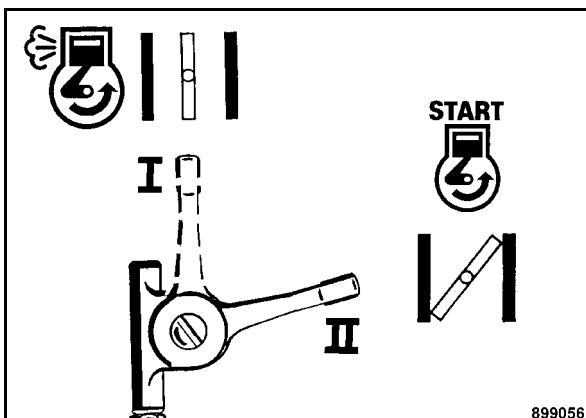

Fig. 21

No. 16 = Choke lever

Position "I" = choke open

Position "II" = choke closed

i Note

Always close the choke if the engine is cold or has cooled down.

Always open the choke when the engine is warm.

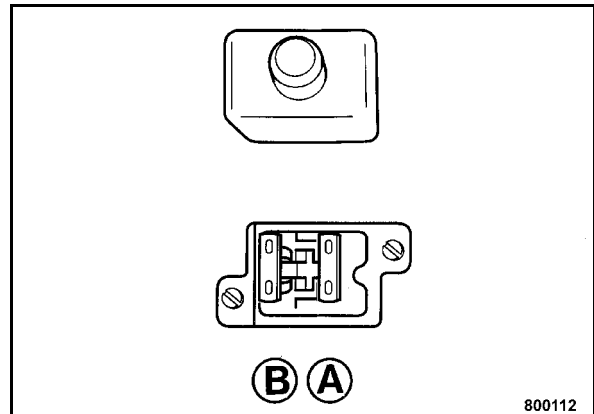

Fig. 22

No. 17 = Fuses

▲ Danger

Fire hazard!

Do not use fuses with higher ampere ratings and do not bridge fuses.

(A) 25A = (F103) Fuse potential 15

(B) 25A = (F111) Regulator

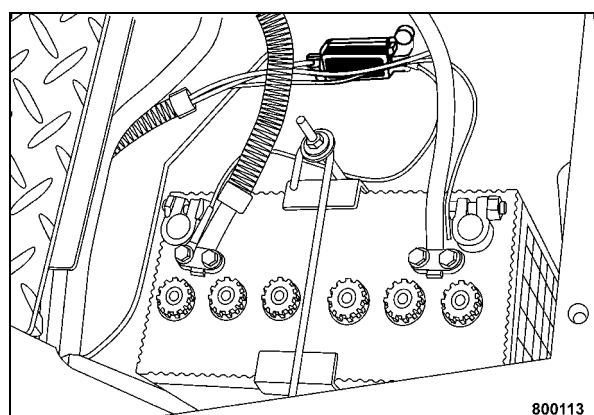

Fig. 23

Main fuse for battery

30A = Main fuse for battery

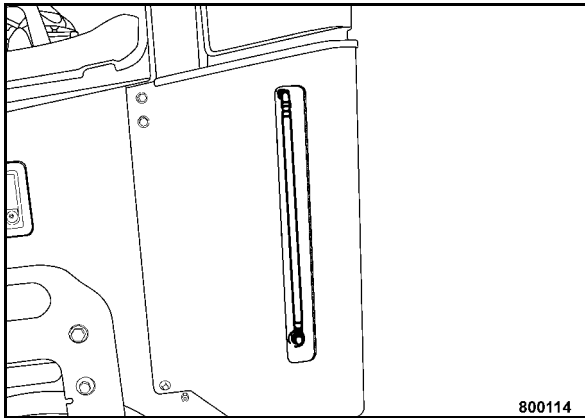

Fig. 24

No. 18 = Water level gauge



4 Operation

4.1 General notes

Please read section 3 Indicators and Control Elements thoroughly before operating the machine if you are not yet fully familiar with the indicators and control elements of the machine.

All indicators and control elements are described in detail in this chapter.

4.2 Tests before starting to operate

The following inspections must be carried out before each working day or before a longer working period.

Danger

Danger of accident!

Please observe strictly the safety regulations in chapter 2 of this instruction manual!

- Park the machine on ground as level as possible.

Check:

- fuel tank and fuel lines for leaks
- bolted connections for tight fit
- function of steering
- machine for cleanliness, damage
- availability of the appropriate operating and maintenance instructions,
- check whether the machine has been properly serviced
- engine oil drain hose plug tight

Note

For a description of the following tasks refer to the chapter "maintenance every 10 operating hours".

- Engine oil level
- Hydraulic oil level, if necessary fill up
- Hydraulic oil filter contamination indicator

Danger

Fire hazard!

Do not refuel in closed rooms.

- Fuel level, if necessary fill up.
- Water level in sprinkler system, if necessary fill up.
- Scrapers, if necessary adjust.

4.3 Starting the engine

▲ Danger

Danger of accident!

Always wear your seat belt.

Start the engine only from the operator's seat.

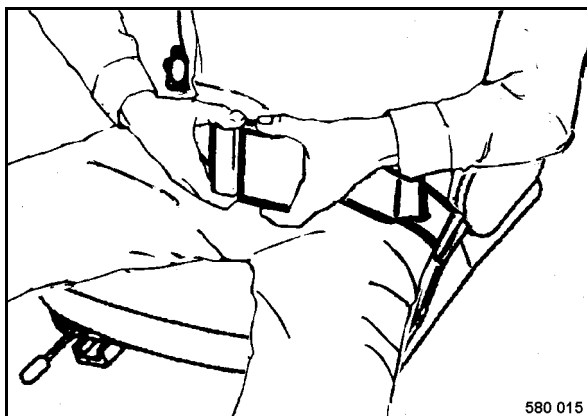

Fig. 25

- Put your seat belt on (Fig. 25).

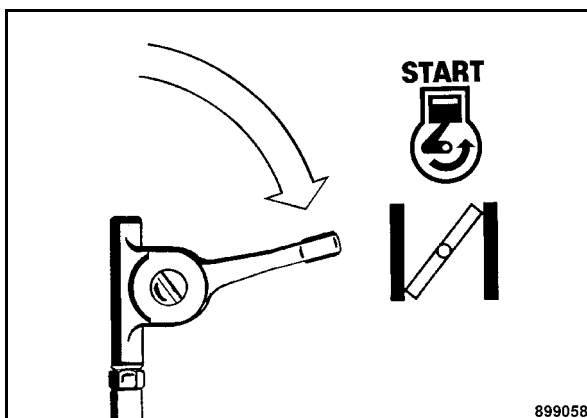

Fig. 26

- Close the choke (Fig. 26).

i Note

Always close the choke if the engine is cold or has cooled down.

Always open the choke when the engine is warm.

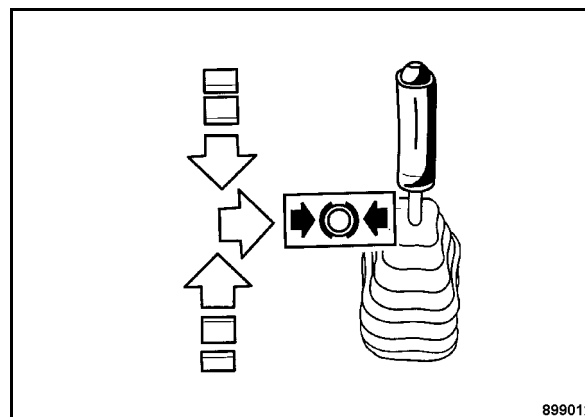

Fig. 27

- Check, whether the travel lever (Fig. 27) is locked to the right in braking position.

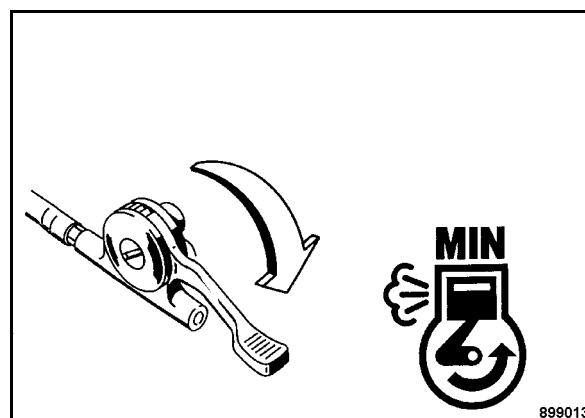

Fig. 28

- Shift the throttle lever (Fig. 28) to position "MIN".

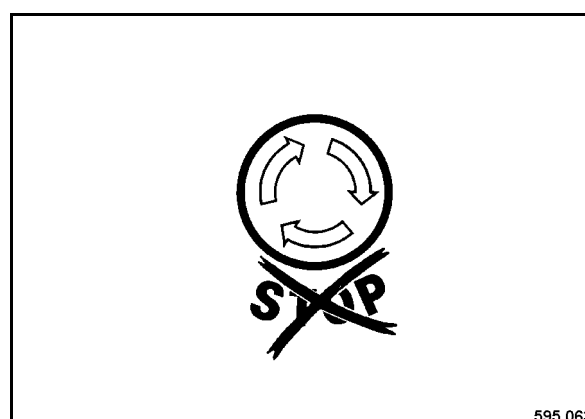

Fig. 29

- Check, whether the emergency stop switch (Fig. 29) is unlocked.

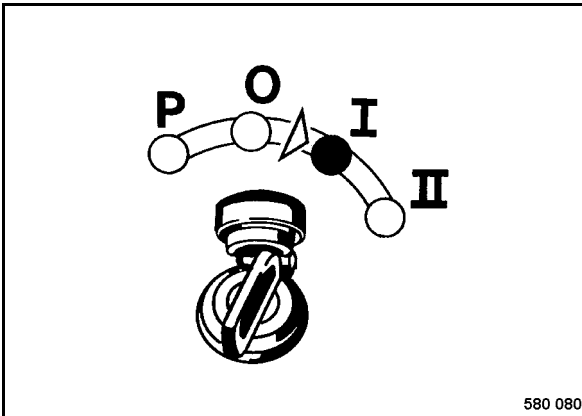

Fig. 30

- Turn the ignition key (Fig. 30) to position "I".

⚠ Caution

Do not attempt to start for longer than 20 seconds without interruption, but interrupt the starting process for a minute.

If the engine has not started after two attempts perform troubleshooting.

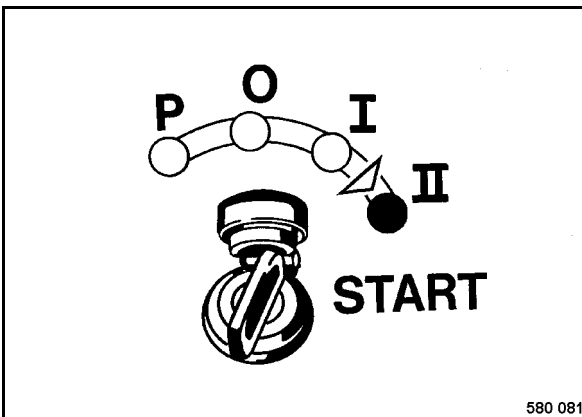

Fig. 31

- Turn the ignition key (Fig. 31) to position "II", the starter will crank the engine.
- As soon as the engine ignites return the ignition key to position "I".

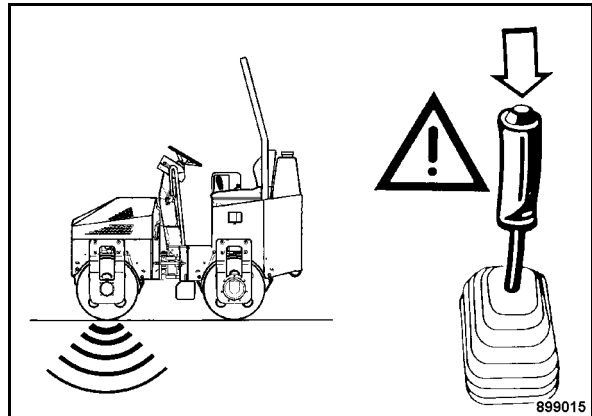

Fig. 32

- If the vibration starts to run after starting the engine, press the vibration push button (Fig. 32) immediately to switch the vibration off.

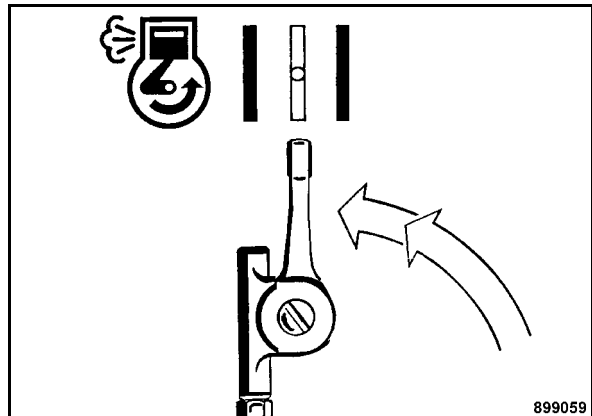

Fig. 33

- Open the choke (Fig. 33) slowly.

⚠ Caution

Run the engine warm for a short while, but do not run with idle speed for more than 10 minutes.

4.4 Starting with jump leads

⚠ Caution

Wrong connection will cause severe damage to the electrical system.

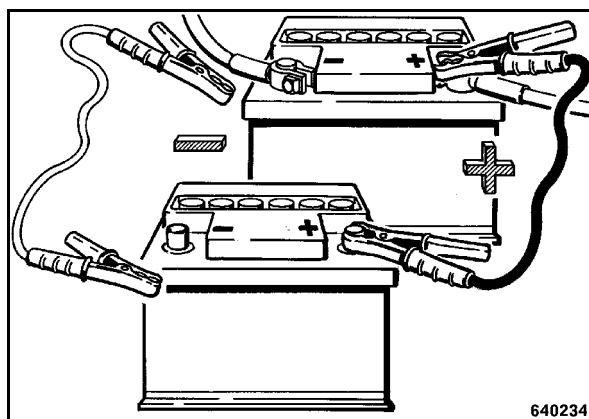

Fig. 34

- When starting with an external battery connect both plus poles (Fig. 34) first and both minus poles (earth cable) after.
- Perform all steps as described in the previous section.
- After starting disconnect the minus poles (earth cable) first and the plus poles after.

4.5 Driving the machine

⚠ Danger

Danger of accident!

Wet and loose soils considerably reduce the ground adhesion of the machine on inclinations and slopes.

Soil conditions and weather influences impair the gradability of the machine.

Do not drive up and down inclinations exceeding the maximum gradability of the machine (see technical data).

Never drive without fastening your seat belt.

Always give way to loaded transport vehicles!

Before starting to drive make sure that the drive range is free of dangers.

Drive and operate the machine only from the driver's seat.

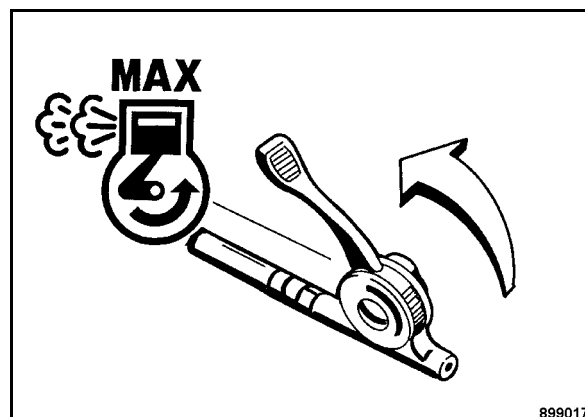

Fig. 35

- Shift the throttle lever (Fig. 35) to position "MAX".

i Note

During operation the throttle lever must always be maintained in full engine speed position.

Control the travel speed only with the travel lever.

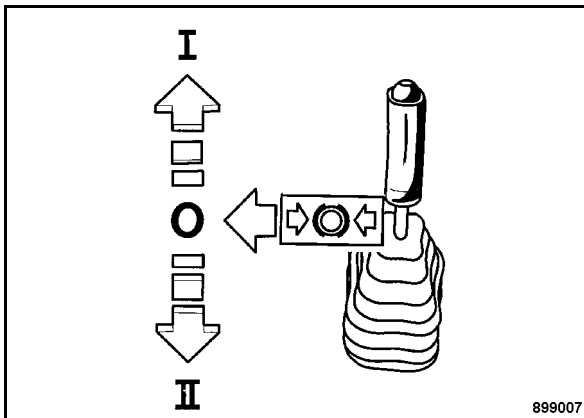

Fig. 36

⚠ Caution

When reversing the travel direction hold the travel lever for a moment in "0"-position, until the machine has come to a halt, then shift to the new direction.

- Unlock the travel lever (Fig. 36) by shifting it to the left out of braking position and move it slowly to the desired travel direction.

Position "I" = max. speed in forward

Position "II" = max. speed in reverse

4.6 Stopping the machine, operating the parking brake

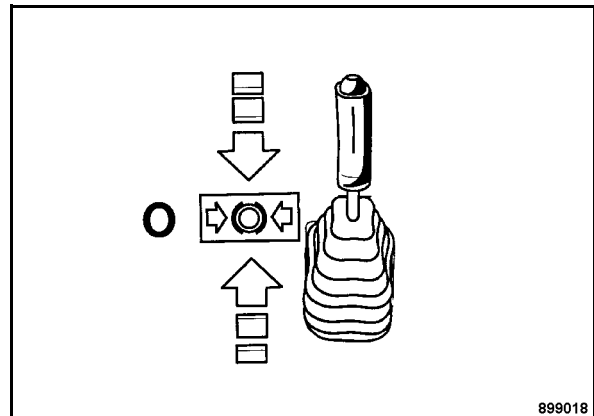

Fig. 37

- Move the travel lever (Fig. 37) to position '0'. The machine is automatically braked by the hydrostatic drive.

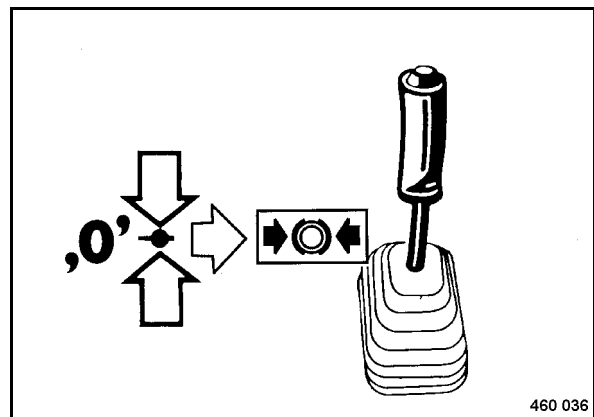

Fig. 38

- Push the travel lever (Fig. 38) to the right into parking brake position.

4.7 Switching the vibration on or off

⚠ Danger

Danger of damage!

When compacting with vibration you must always check the effect of vibration on nearby buildings and underground supply lines (gas, water, sewage, electric power) and stop compaction work with vibration, if necessary.

⚠ Caution

Risk of bearing damage!

Do not switch the vibration on on hard (frozen, concrete) ground.

i Note

Switch the vibration on when the engine is running with full speed.

Vibration at standstill leaves transverse marks in the asphalt, therefore:

- only switch the vibration on after shifting the travel lever to the desired travel direction.
- switch the vibration off before stopping the machine.

Switching the vibration on

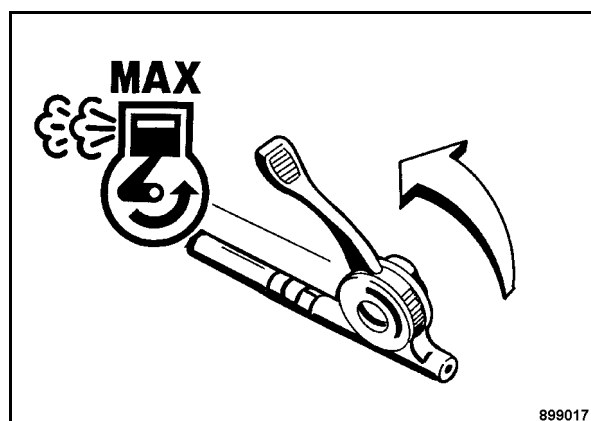

Fig. 39

- Always shift the throttle lever (Fig. 39) to position "MAX".

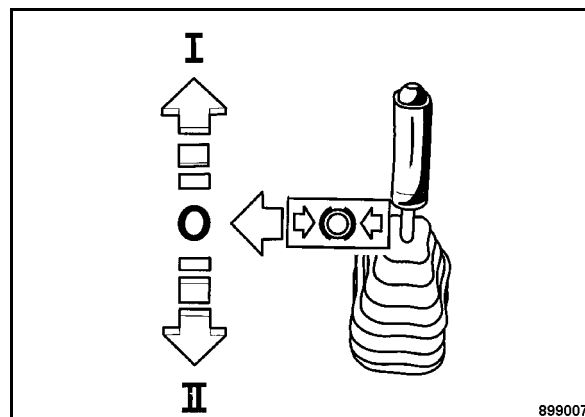

Fig. 40

- Move the travel lever (Fig. 40) slowly to the desired travel direction.

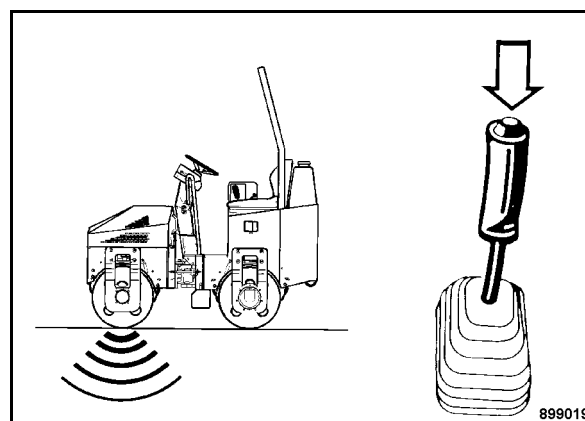

Fig. 41

- Actuate the vibration push button (Fig. 41).

Switching the vibration off

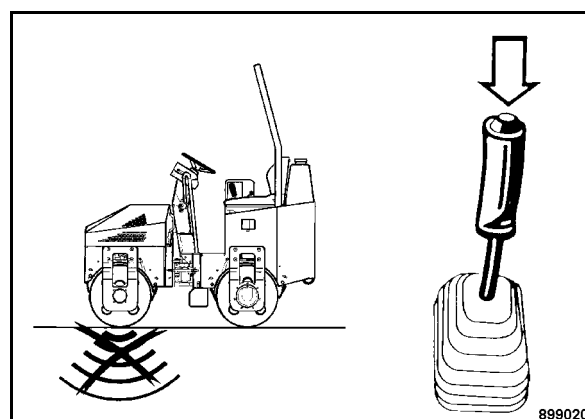

Fig. 42

- Actuate the vibration push button (Fig. 42) again.

4.8 Switching the gravity sprinkler system on or off

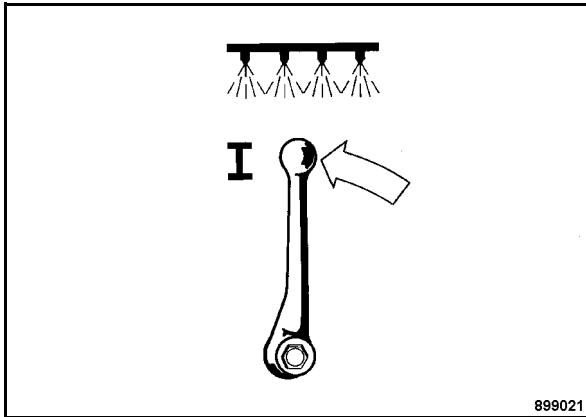

Fig. 43

- Switch the cock valve to position "I" (Fig. 43). The gravity sprinkler system is switched on.

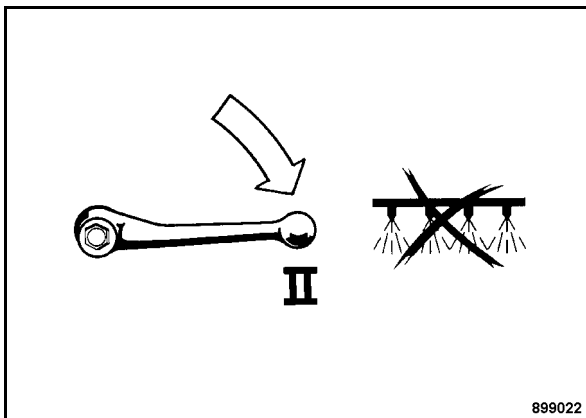

Fig. 44

- Switch the cock valve to position "II" (Fig. 44). The gravity sprinkler system is switched off.

4.9 Stopping the engine/machine

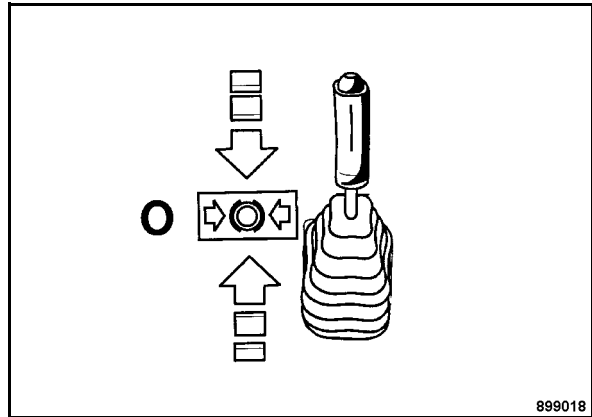

Fig. 45

- Move the travel lever (Fig. 45) to position '0'. The machine is automatically braked by the hydrostatic drive.

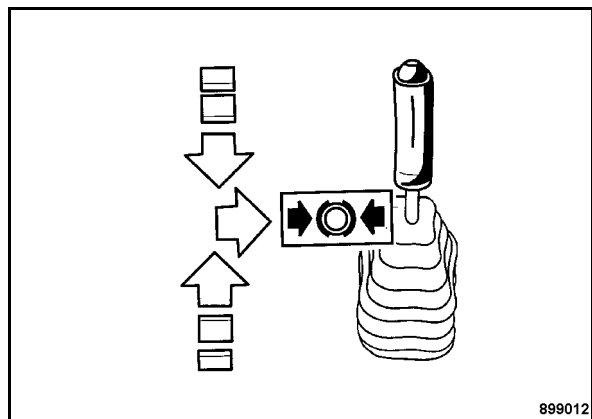

Fig. 46

- Push the travel lever (Fig. 46) to the right into parking brake position.

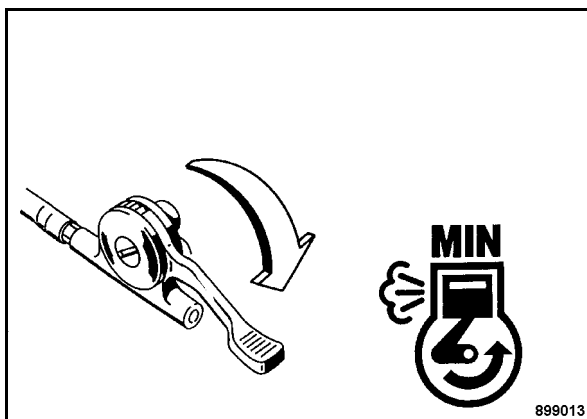

Fig. 47

- Shift the throttle lever (Fig. 47) back to position "MIN".

i Note

Do not shut the engine down all of the sudden from full speed, but let it idle for a while for temperature equalization.

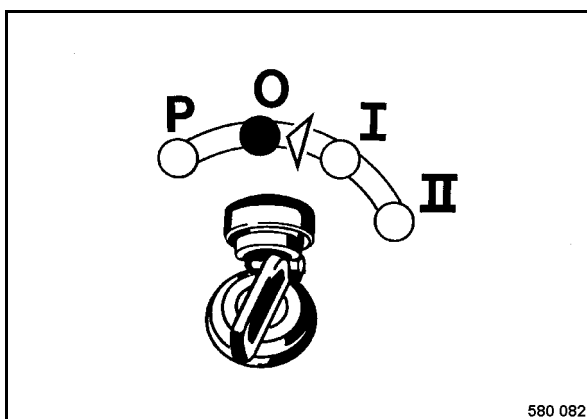

Fig. 48

- Turn the ignition key (Fig. 48) to position "0" to shut the engine down.

▲ Danger

Danger of accident!

Secure the machine against unauthorized use, pull the ignition key off.

- Mark machines, which could be in the way, with a clearly visible sign.

4.10 Adjusting the driver's seat

▲ Danger

Danger of accident!

Never adjust the seat while driving.

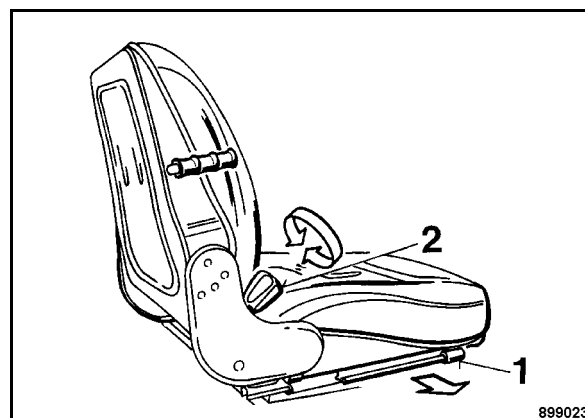

Fig. 49

- To adjust the seat in longitudinal direction push the lever 1 (Fig. 49) outwards.
- Adjust the inclination of the backrest by turning the rotary knob (2).

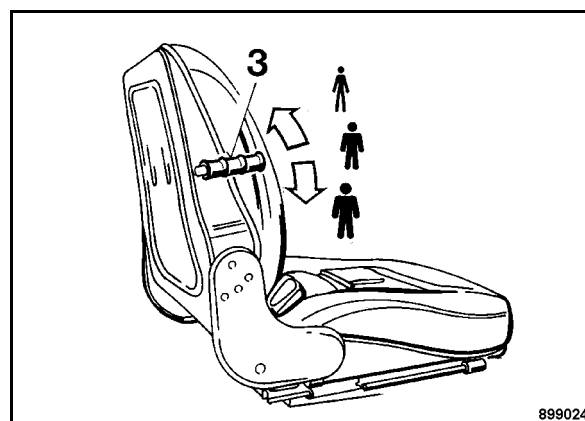

Fig. 50

- Operate lever 3 (Fig. 50) to adjust the seat to the weight of the operator.

4.11 Towing

▲ Danger

Danger of accident!

Secure the machine against unintended rolling.

Releasing the brake

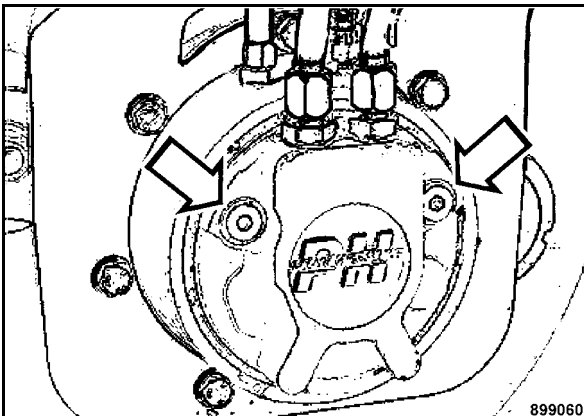

Fig. 51

- Unscrew the two plugs (Fig. 51).

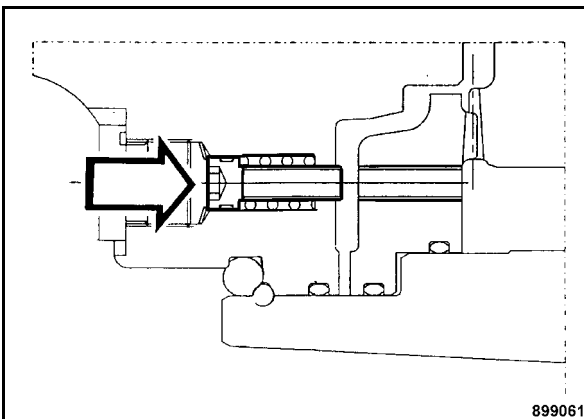

Fig. 52

- Push both screws (Fig. 52) in against the springs.
- Tighten both screws alternately and step by step to 35 Nm (25.7 ftlb).

Towing the machine

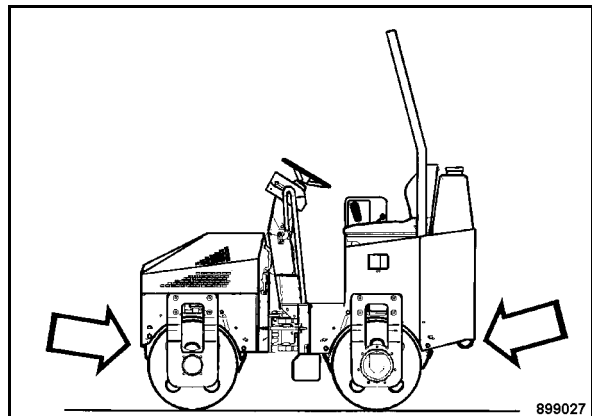

Fig. 53

▲ Caution

You should generally use a tow bar, max. towing speed 1 km/h (1.6 mph), max. towing distance 500 m (1640 ft.).

- Tow the machine by the front or rear towing hitches (Fig. 53).

After towing

▲ Danger

The machine must only be started with the mechanical brake releasing device deactivated.

- Loosen both screws completely (Fig. 52) to apply the brake.
- Turn both plugs back in (Fig. 51).

4.12 Loading and transport

▲ Danger

Mortal danger!

Use only strong and stable loading ramps of sufficient load bearing capacity. Make sure that persons are not endangered by the machine tipping or sliding off.

Tie the machine down, so that it is secured against rolling, sliding and turning over.

Do not stand or step under loads being lifted.

Always use shackles on the lifting points for loading, tying or lifting the machine.

Check the fastening of the central lifting hook before each lifting process.

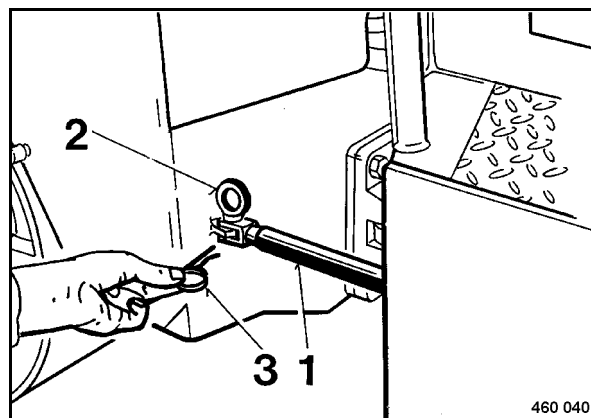

Fig. 54

- After driving the machine on the transport vehicle swing the articulation lock 1 (Fig. 54) out of its receptacle to the front. Insert the pin (2) and secure it with the cotter pin (3).

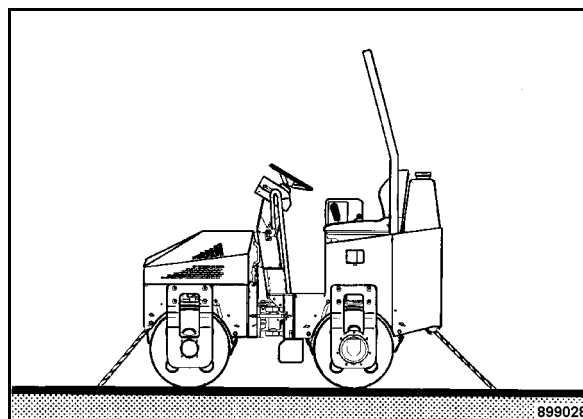

Fig. 55

- Tie the machine to the transport vehicle, attach the tying gear (Fig. 55) to the front and rear frame.

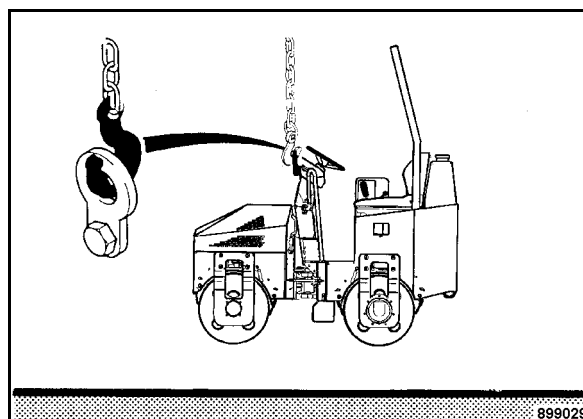

Fig. 56

- Always lift the machine by the central lifting facility (Fig. 56).

Loading weight: See technical data

After transport

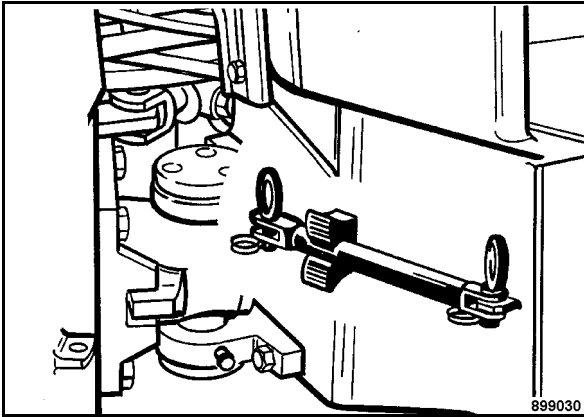

Fig. 57

- After transport release the articulation lock again and store it in the receptacle.

5 Maintenance

5.1 General notes on maintenance

When performing maintenance work always comply with the appropriate safety regulations.

Thorough maintenance of the machine guarantees far longer safe function of the machine and prolongs the lifetime of important components. The effort needed for this work is only little compared with the problems that may arise when not observing this rule.

The terms right/left correspond with travel direction forward.

- Always clean machine and engine thoroughly before starting maintenance work.
- For maintenance work stand the machine on level ground.
- Perform maintenance work generally with the engine stopped.
- Relieve hydraulic pressures before working on hydraulic lines.
- Before working on electric parts of the machine disconnect the battery and cover it with insulation material.
- When working in the area of the articulated joint attach the articulation lock (transport lock).
- During maintenance work catch all oils and fuels and do not let them seep into the ground or into the sewage system. Dispose of oils and fuels environmentally.

Notes on the fuel system

The lifetime of your engine depends to a great extent on the cleanliness of the fuel.

- Keep fuel free of contaminants and water, since this could destroy the engine.
- Internally zinc coated drums are not suitable for storing fuel.
- The fuel drum should rest for quite some time before drawing off fuel.
- Do not stir up the slurry at the bottom of the drum with the suction hose.

- Do not draw off fuel from near the bottom of the drum.
- Fuel left in the drum is not suitable for the engine and should only be used for cleaning purposes.

Notes on the engine performance

Combustion air and fuel calibration rates of the engine have been carefully adjusted and determine the engine's performance and temperature level as well as the quality of the exhaust gas.

If your machine has to work permanently in "thin air" (at high altitudes) and with full power, you should consult the after sales service of BOMAG or the service department of the engine manufacturer.

Notes on the hydraulic system

Cleanliness is of utmost importance when servicing hydraulic systems. Make sure that no dirt or other contaminating substances enter into the system. Small particles can flut valves, cause pumps to seize and block restrictors and pilot bores, thereby causing costly repairs.

- If, during the daily inspection of the oil level the hydraulic oil level is found to have dropped, check all lines, hoses and components for leaks.
- Seal external leaks immediately. If necessary inform the after sales service of BOMAG.
- Do not store drums with hydraulic oil outside, or store them at least under a cover. With changing weather water can penetrate through the bung hole.
- Always use the filling and filtering unit (BOMAG part-no. 007 610 01) to fill the hydraulic system. This unit is fitted with a fine filter, which cleans the hydraulic oil and thereby prolongs the lifetime of the system filter.
- Clean fittings, filler caps and their immediate surrounding area before removing them, so that no dirt can fall in.
- Do not leave the tank opening unnecessarily open, cover it so that no dirt can fall in.

5.2 Fuels and lubricants

Engine oil

To ensure perfect cold starting it is important to choose the viscosity (SAE-class) of the engine oil with respect to the ambient temperature.

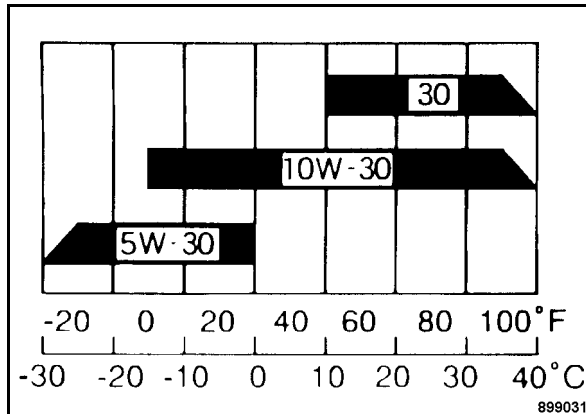

Fig. 58

Lubrication oil with a too high viscosity index causes starting difficulties. The temperature when starting the engine is therefore of highest importance when choosing the viscosity of engine oil for winter operation.

Oil viscosity

Since the viscosity of lubrication oil changes with the temperature, the ambient temperature at the engine's operating location determines the viscosity class (SAE-grade) to be chosen (see diagram).

Occasional falling short of the temperature limit (e.g. use of SAE 10W/30 down to -15 °C) may affect the cold starting ability of the engine, but will not cause any engine damage.

Temperature related lubrication oil changes can be avoided by using multi-purpose oils. The following oil change intervals apply also when using multi-purpose oils.

Regular lubrication oil changes

The longest permissible time a lubrication oil should remain in an engine is 1 months. If the following oil change intervals are not reached over a period of 1 months, the oil change should be performed at least every 3 months, irrespective of the operating hours reached.

Oil quality

Lubrication oils are classified according to their performance and quality class. Specifications according to API (American Petroleum Institute) and CCMC (Committee of Common Market Automobile Constructors) are commonly used.

Permitted API-oils

SF/SG

Lubrication oil change intervals

SF/SG = 125 operating hours

Fuels

Quality

Use only commercial brand unleaded gasoline with a pump octane rating of 86 or higher.

Hydraulic oil

The hydraulic system works with hydraulic oil HV 32 (ISO) with a kinem. viscosity of 32 mm²/s at 40°C. For topping up or for oil changes use only high-quality hydraulic oil, type HVLP according to DIN 51524, part 3, or hydraulic oils type HV according to ISO 6743/3. The viscosity index (VI) should be at least 150 (observe information of manufacturer).

Lubrication grease

For lubrication use only EP-high pressure grease, lithium saponified (penetration 2).

5.3 Fuels, lubricants and filling capacities

Assemblies	Fuels, Lubricants		Approx. quantity
	Summer	Winter	Attention Observe level marks
Engine	Engine oil API: SF/SG SAE 10W/30 (-15 °C to +40 °C)		1.5 l (0.4 USgal) up to dipstick mark max.
Hydraulic system	Fuel unleaded standard grade gasoline hydraulic oil (ISO), HV32, kinematic viscosity 32 mm ² /s at 40 °C		30 litres (8 USgal) to middle of dipstick approx. 15 litres (4 USgal) (tank capacity)
Sprinkler system	water	anti-freeze mixture water**	as required 180 litres (48 USgal)
Oscillating articulated joint	high pressure grease (lithium saponified)		as required

**Mix water an anti-freeze agent according to the specifications of the manufacturer

5.4 Running-in instructions

Maintenance after 20 operating hours

The following work should be generally be carried out on new or overhauled engines:

- Change engine oil
- Check engine for leaks
- Retighten the fastening screws on air filter, exhaust and other attachments.

Maintenance up to 200 operating hours

- New engines normally have a higher fuel consumption. We recommend to check the oil level twice every day during the running-in period.
- After the running-in period it is sufficient to check the oil level only once every day.
- Check bolted connections on the machine, retighten if necessary.
- Check for leaks.

5.5 Maintenance table

With all maintenance intervals perform also the work for shorter preceding service intervals.

Pos.	Description	Note
Every 10 operating hours		
5.6	Checking the engine oil level	
5.7	Checking the fuel level	
5.8	Checking the hydraulic oil level	to middle of dipstick mark
5.9	Checking the hydraulic oil filter element	Contamination indicator
5.10	Checking the water level in the sprinkler system	Summer: Water Winter: Anti-freeze mixture
5.11	Checking, cleaning the scrapers	
5.12	Cleaning the cooling air intake openings	
Every 125 operating hours		
5.13	Lubricating the articulated joint	High pressure grease
5.14	Cleaning the air filter	
5.15	Cleaning, checking or changing the spark plugs	
5.16	Changing the engine oil (at least 1x per year)	to top dipstick mark
Every 250 operating hours		
5.17	Changing the engine oil filter	
5.18	Cleaning the sprinkler system	
Every 500 operating hours		
5.19	Changing the fuel pre-filter	
5.20	Servicing the battery	greasing the poles
5.21	Checking, adjusting the valve clearance	
5.22	Changing the air filter	
Every 2000 operating hours		
5.23	Changing the hydraulic oil*	at least every 2 years
5.24	Changing the hydraulic oil filter*	at least every 2 years
As required		
5.25	Water sprinkler system, maintenance in case of frost	
5.26	Tightening torques for screws with metric unified thread	
5.27	Engine conservation	

*Also in case of repairs in the hydraulic system.

5.6 Checking the engine oil level

i Note

Park the machine on level ground so that the engine is in horizontal position.

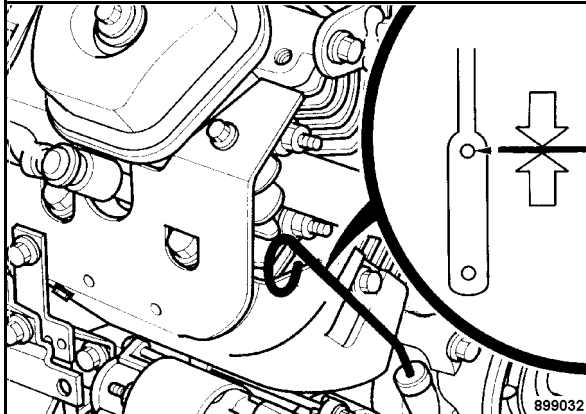

Fig. 59

- Shut the engine down.
- Pull the dipstick (Fig. 59) out, wipe it off with a lint-free, clean cloth and reinsert it until it bottoms.
- Pull the dipstick back out.
- The oil level must reach the top mark.
- If the oil is below this level top up oil immediately.

For quality and quantity of oil refer to the table of "fuels and lubricants".

- Check the oil level again after running the engine for approx. 1 minute.

5.7 Checking the fuel level

▲ Danger

Fire hazard!

Do not inhale any fuel fumes.

When working on the fuel system do not use open fire, do not smoke.

Do not refuel in closed rooms.

▲ Caution

Contaminated fuel can cause malfunction or even damage of the engine.

If necessary fill in fuel through a screen filter or use a fuel gun.

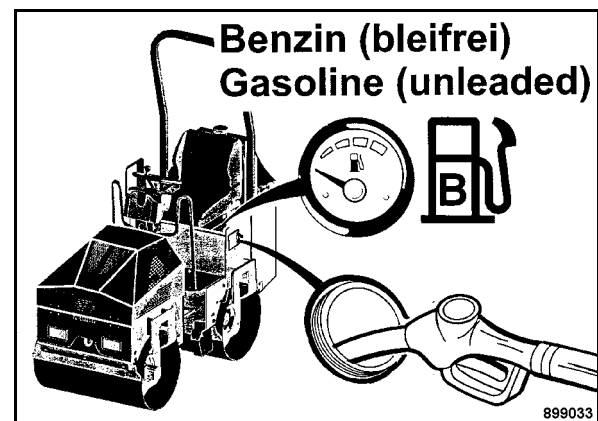

Fig. 60

- Check the fuel level in the fuel gauge (Fig. 60).
- Clean the area around the fuel filler neck.
- Open the filler cap on the fuel tank.
- If necessary fill in fuel.

For quality of fuel refer to the table of fuels and lubricants.

5.8 Checking the hydraulic oil level

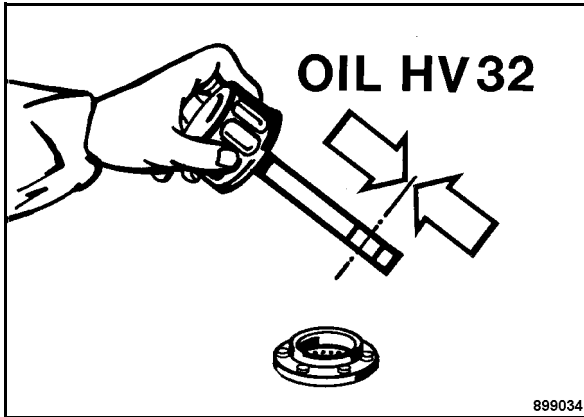

Fig. 61

- Clean the area around the fuel filler neck.
- Remove the filler cap.
- Check the hydraulic oil level on the dipstick. The oil level must be between the 'MIN' and 'Max' marks.
- If the oil is below this level fill in hydraulic oil.

For quality and quantity of oil refer to the table of "fuels and lubricants".

i Note

If, during the daily inspection of the oil level the hydraulic oil level is found to have dropped, check all lines, hoses and components for leaks.

5.9 Checking the hydraulic oil filter element

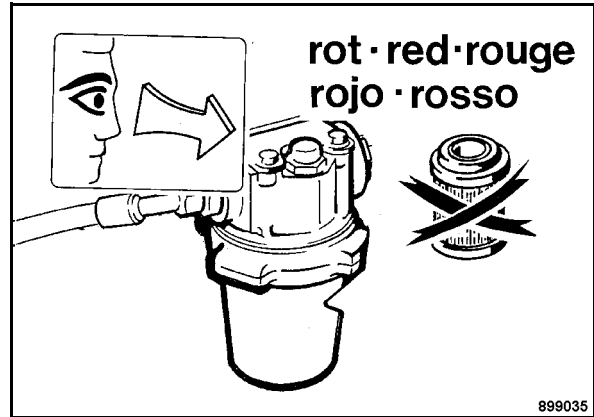

Fig. 62

- Check the hydraulic oil filter contamination indicator at operating temperature and at maximum engine speed.
- If the optical display (Fig. 62) shows red, the hydraulic oil filter element must be changed.

i Note

After changing the dirty filter the optical display appears green.

5.10 Check the water level

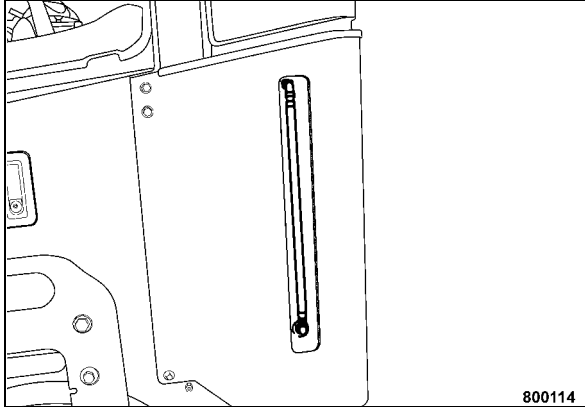

Fig. 63

- Check the water level (Fig. 63).

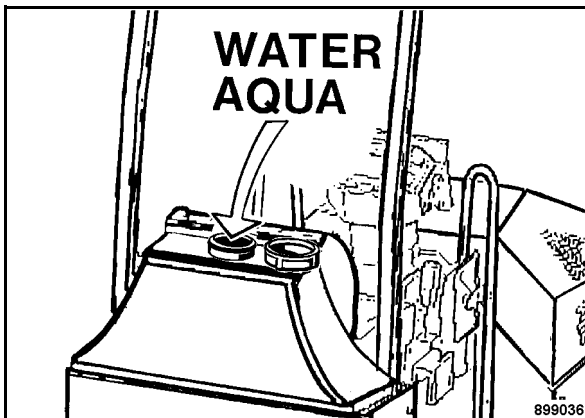

Fig. 64

- Open the lid (Fig. 64) and fill in as much water as is required, close the lid.

i Note

If there is a risk of frost observe the special service instructions under "water sprinkler system, maintenance in case of frost".

Make sure that the ventilation bore in the filler cap is free.

5.11 Cleaning the scrapers

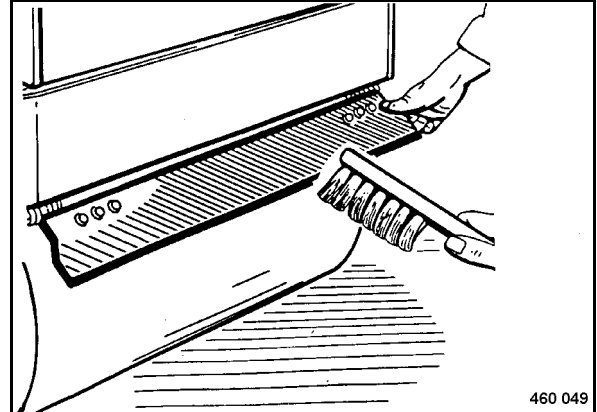

Fig. 65

- Fold the scrapers up and clean them (Fig. 65). This is of particular importance before compacting asphalt surfaces.

5.12 Cleaning the cooling air intake opening

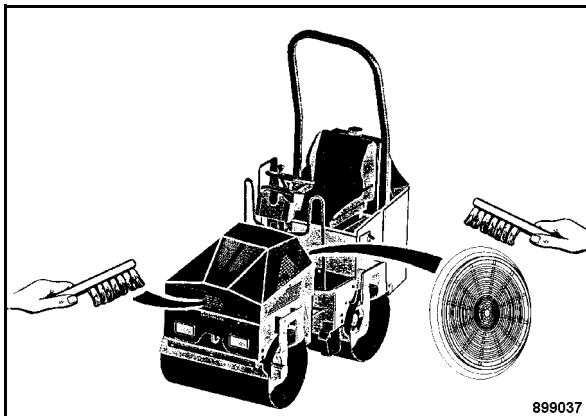

Fig. 66

i Note

Dirt in the cooling air intake openings reduces the cooling effect.

- Clean the cooling air intake openings (Fig. 66).

5.13 Greasing the articulated joint

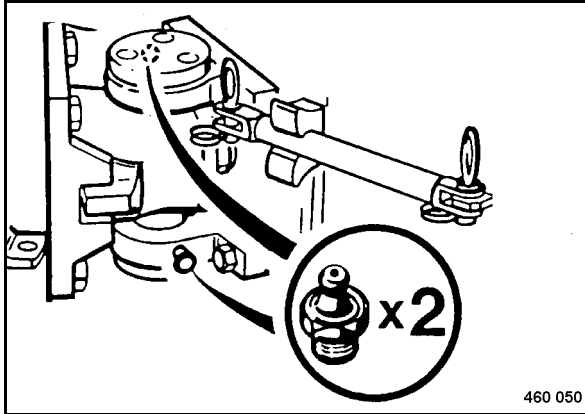

Fig. 67

- Clean the grease nipples (Fig. 67) and lubricate with approx. 5 strokes from the grease gun.

For quality of oil refer to the section about fuels, lubricants and filling capacities.

5.14 Checking, cleaning the dry air filter

⚠ Caution

A dirty dry air filter cartridge can be noticed by excessive exhaust smoke.

A dry air filter cartridge with a damaged filter element or seal ring must be replaced in any case. It is therefore recommended to keep at least one cartridge in stock.

The dry air filter cartridge must be changed after 500 operating hours, but at the latest after 1 year.

Cleaning does not make sense if the air filter element is covered with a sooty deposit. Use a new filter cartridge.

Incorrectly handled filter cartridges may be ineffective if damaged (e.g. cracks) and cause damage to the engine.

Always replace the filter cartridge if it is soiled with wet or oily dirt.

Do not use gasoline or any hot fluids to clean the filter cartridge.

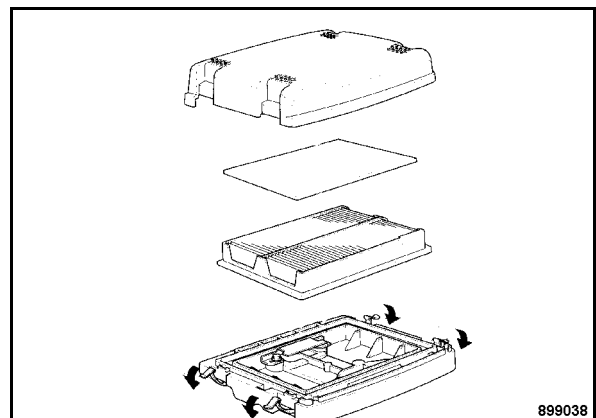
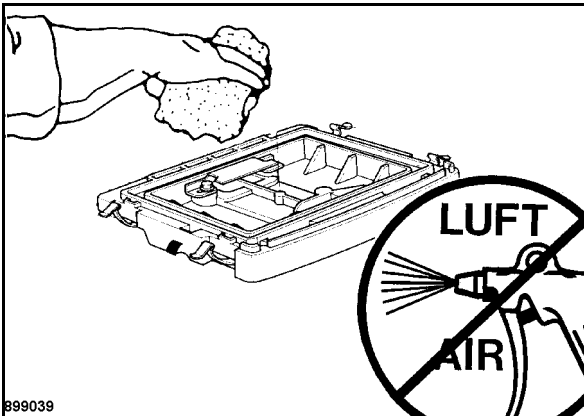

Fig. 68

- Remove the cover and take the air filter cartridge with foam insert (Fig. 68) out of the air filter housing cover.

Every 125 operating hours



899039

Fig. 69

- Clean the air filter housing with a clean cloth (Fig. 69).

Caution

Do not blow the filter housing out with compressed air.

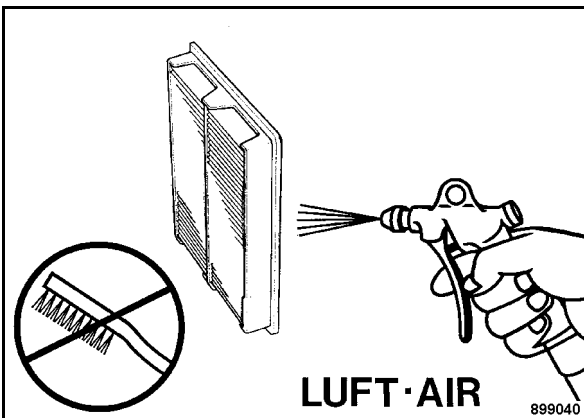

899040

Fig. 70

Danger

Eye injury!

Wear goggles.

- Blow the dry air filter (Fig. 70) out with clean and dry compressed air with a pressure of max. 2.1 bar.

Caution

Do not hold the pressure air nozzle closer than 3 cm to the filter

- Always blow along the inside creases.
- Replace a damaged dry air filter immediately.

Wet cleaning:

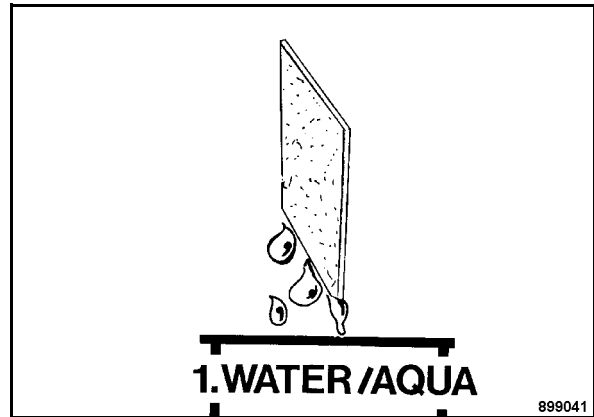

899041

Fig. 71

- Clean the foam filter by moving it to and fro in luke-warm water containing commercial detergent. Then rinse it thoroughly in clear water, shake all water off and let it dry properly (Fig. 71).

Caution

Do not use gasoline or any hot fluids to clean the filter cartridge.

- Before inserting the cartridge check the sealing faces on the dry air filter.

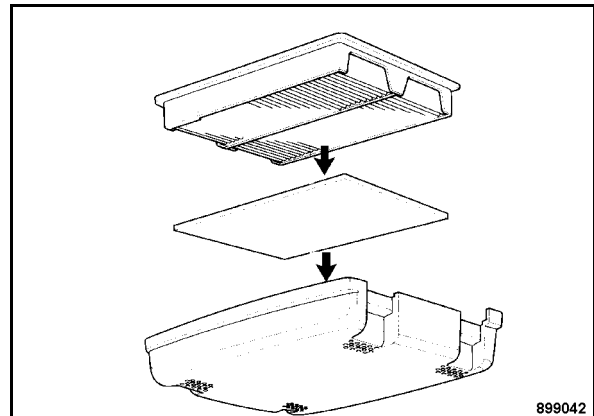

899042

Fig. 72

- Lay the foam insert into the air filter cartridge into the air filter housing cover and then install the air filter cartridge (Fig. 72).
- Attach the air filter housing cover to the air filter housing and lock it with the hooks.

5.15 Cleaning, checking the spark plug

⚠ Danger

Danger of burning on the hot engine!

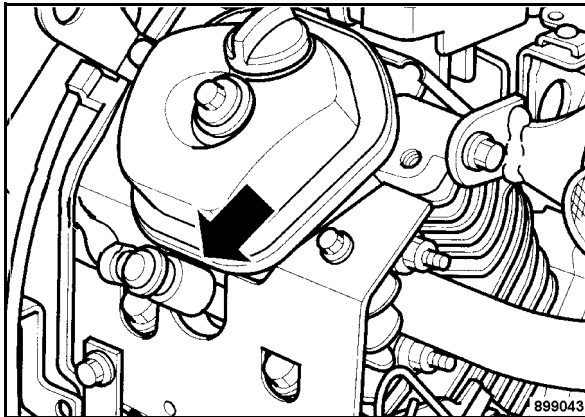

Fig. 73

- Pull the spark plug socket off and unscrew the spark plug (Fig. 73).

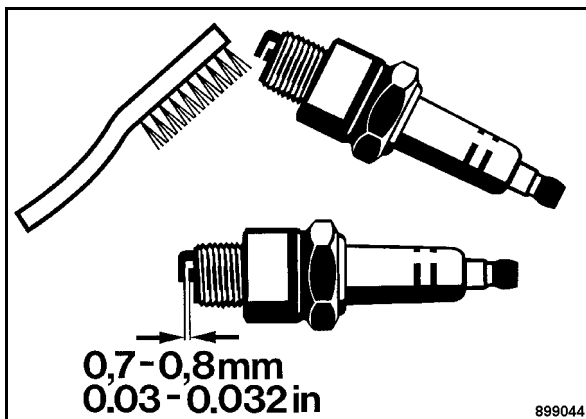

Fig. 74

- Check the spark plug and clean if necessary (Fig. 74).

i Note

In case of excessive combustion residuals or burned off electrodes replace the spark plug, ensure correct heat value of the spark plug.

- Check the electrode gap with a feeler gauge, if necessary adjust the gap to 0,7 to 0,8 mm (.03 to .032 in).

5.16 Changing the engine oil

⚠ Caution

Drain the engine oil only when the engine is warm.

⚠ Danger

Danger of scalding!

When draining hot oil.

♻ Environment

Catch old oil and dispose of environmentally.

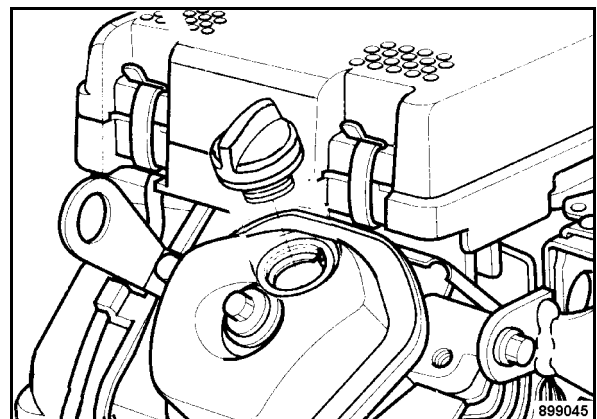

Fig. 75

- Remove the cover from the oil filler opening (Fig. 75).

Every 125 operating hours

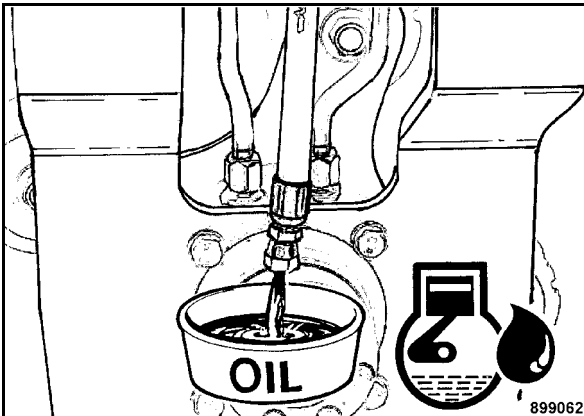

Fig. 76

- Unscrew oil drain plug (Fig. 76) from the drain hose and catch the old oil.
- Screw the drain plug back in with a new seal ring.

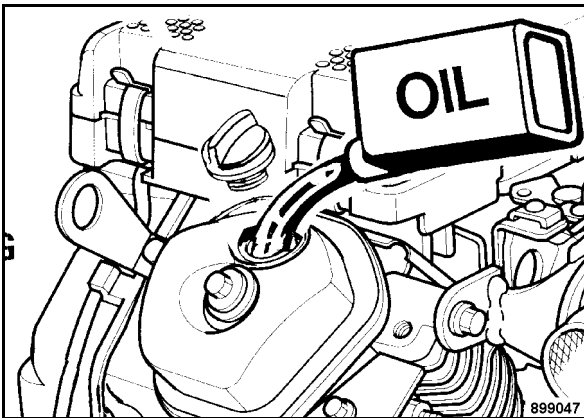

Fig. 77

- Fill in new engine oil (Fig. 77).

For quality and quantity of oil refer to the table of "fuels and lubricants".

- Screw the cap on the oil filler neck.

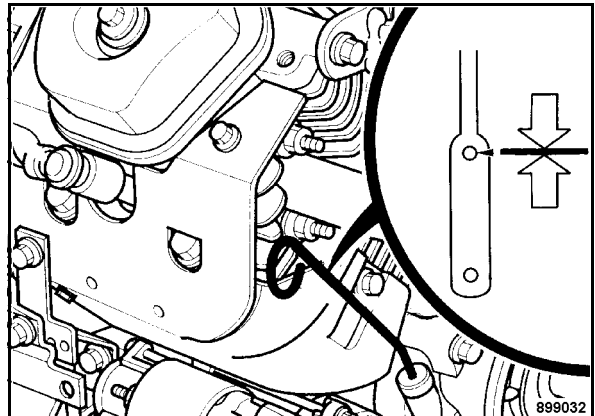

Fig. 78

- Check the oil level on the dipstick (Fig. 78) after a short test run. The oil level must reach the top mark, fill in oil if necessary.

5.17 Changing the engine oil filter

⚠ Danger

Danger of burning!

Danger of scalding by hot oil when changing the engine oil filter.

♻ Environment

Environmental damage

Catch the oil and dispose of environmentally together with the engine oil filter cartridge.

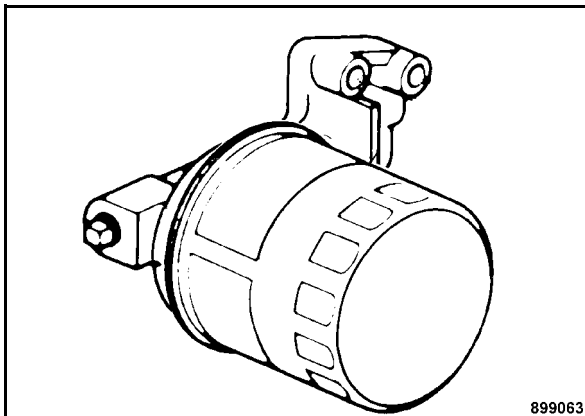

Fig. 79

- Loosen the engine oil filter cartridge (Fig. 79) with a suitable filter wrench and unscrew it.
- Wipe the sealing face on the engine clean.

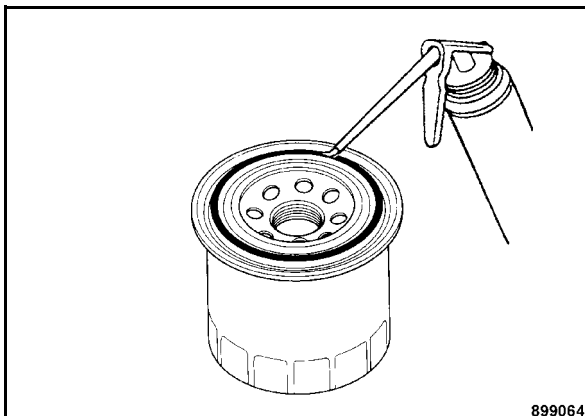

Fig. 80

- Apply some clean oil to the rubber seal of the new filter cartridge (Fig. 80).

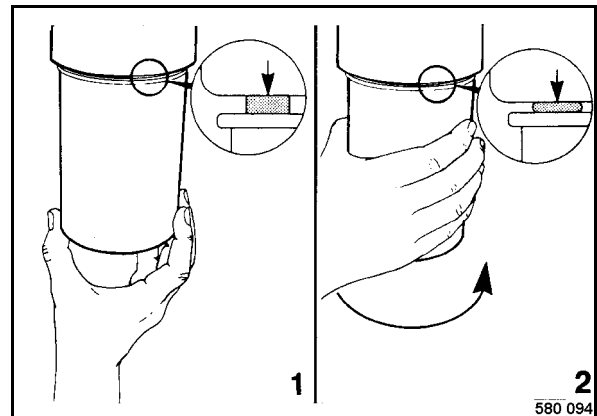

Fig. 81

- Turn the new filter cartridge on and tighten it hand tight (Fig. 81).
- Perform a short test run and check for leaks, if necessary fill up oil.

5.18 Changing the fuel pre-filter

⚠ Danger

Fire hazard!

When working on the fuel system do not use open fire, do not smoke.

Do not spill any fuel.

⚠ Caution

Environmental damage!

Catch running out fuel, do not let it seep into the ground.

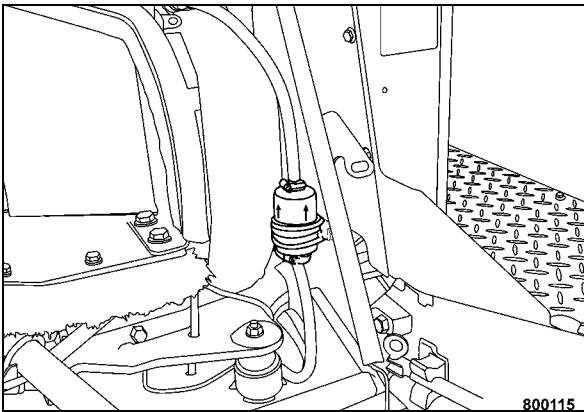

Fig. 82

- Loosen the hose clamps (Fig. 82).
- Pull the fuel filter out of the top and bottom hoses.

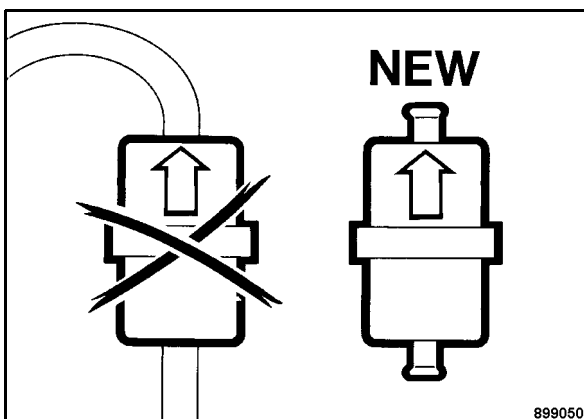

Fig. 83

- Install the new fuel filter and observe the flow direction (Fig. 83).

5.19 Cleaning the sprinkler system

i Note

In the event of frost observe the special service notes "water sprinkler system, maintenance in case of frost".

- Empty the water tank.

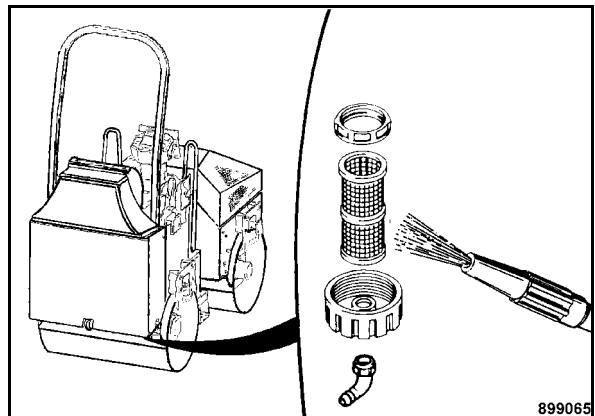

Fig. 84

- Unscrew the spigot nut from the hose (Fig. 84).
- Unscrew and clean the water filter.
- Flush the water tank thoroughly.
- Reinstall the water filter, tighten the spigot nut.

Right hand side

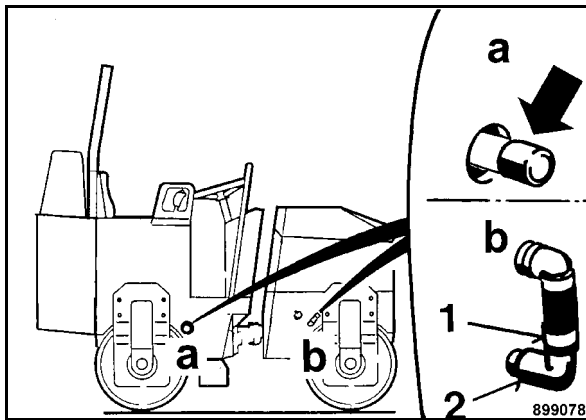

Fig. 85

- Pull the cap a (Fig. 85) off the sprinkler tube.
- Loosen (b) the hose clamp (1) and pull the hose off the sprinkler tube (2).

Left hand side

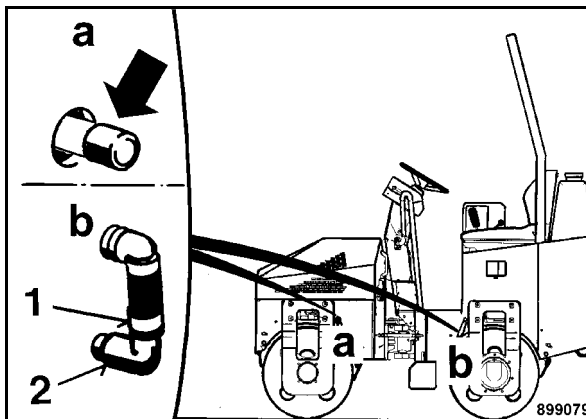

Fig. 86

- Pull the cap a (Fig. 86) off the sprinkler tube.
- Loosen (b) the hose clamp (1) and pull the hose of the sprinkler tube (2).
- Pull the sprinkler tubes out and flush them thoroughly.
- Insert the sprinkler tubes and fill the water tank.

5.20 Checking the condition of the battery, greasing the poles

⚠ Danger

Causticization, danger of explosion!

When working on the battery do not use open fire, do not smoke.

Do not let acid come in contact with hands or clothes!

Wear goggles!

Do not lay any tools on the battery!

For recharging remove the plugs from the battery to avoid the accumulation of highly explosive gases.

♻ Environment

Dispose of old batteries environmentally.

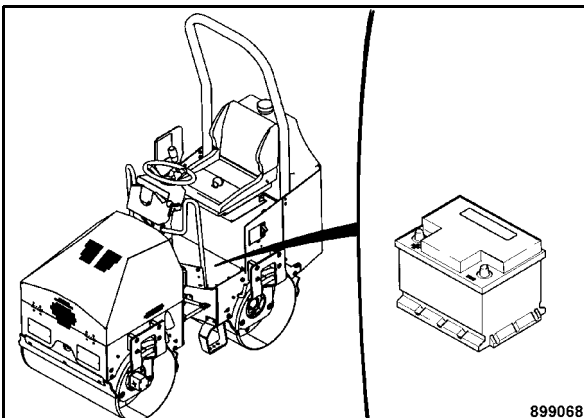

Fig. 87

- Remove the cover in the foot area (Fig. 87).

Maintenance-free batteries:

- Clean battery and battery compartment.
- Clean battery poles and terminal clamps and grease them with pole grease (Vaseline).
- Tighten the terminal clamps.
- Check the fastening of the battery.

Serviceable batteries:

- Clean battery and battery compartment.

⚠ Caution

Use only distilled water to fill up missing fluid.

- Open the plugs and check the acid level, if necessary fill up with distilled water.

With control inserts

- The acid level must reach the bottom of the control inserts.

Without control inserts

- The acid level must be 10 to 15 mm above the upper edge of the lead plate.

i Note

Measure the acid level with a clean wooden stick.

With transparent battery housing

- The acid level must reach the top mark on the housing.
- Clean battery poles and terminal clamps and grease them with pole grease (Vaseline).
- Tighten the terminal clamps.
- Check the fastening of the battery.

i Note

When using Delco batteries check the function by visual inspection on the integrated hydrometer.

5.21 Checking, adjusting the valve clearance

i Note

Check and adjust only when the engine is cold.

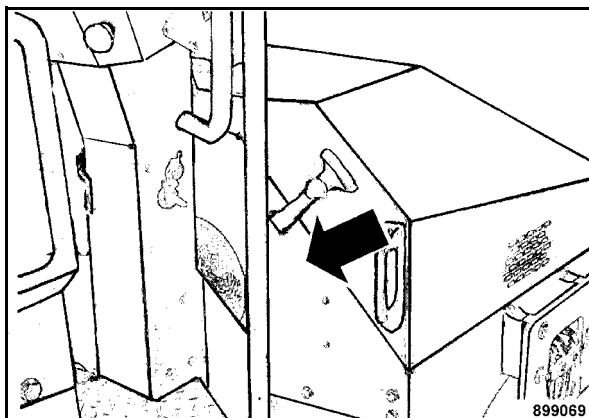

Fig. 88

- Open the engine compartment flap and remove the back wall (Fig. 88).

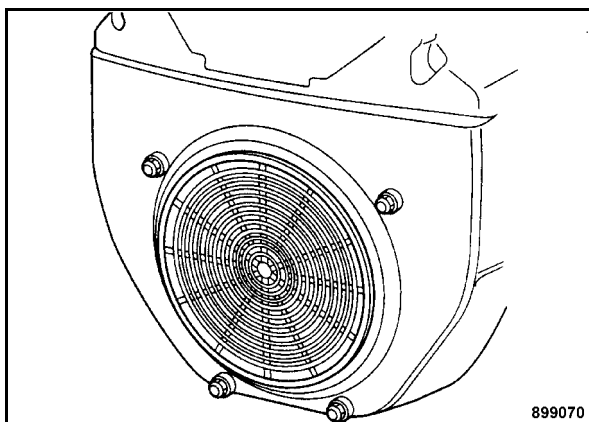
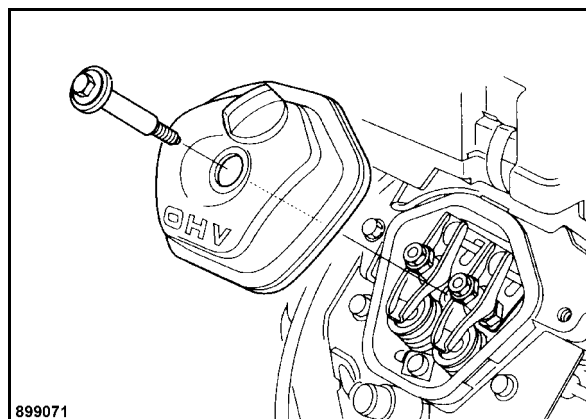

Fig. 89

- Remove the grid (Fig. 89).



899071

Fig. 90

- Unscrew the fastening screws for the cylinder head cover and take both cylinder head covers off (Fig. 90).

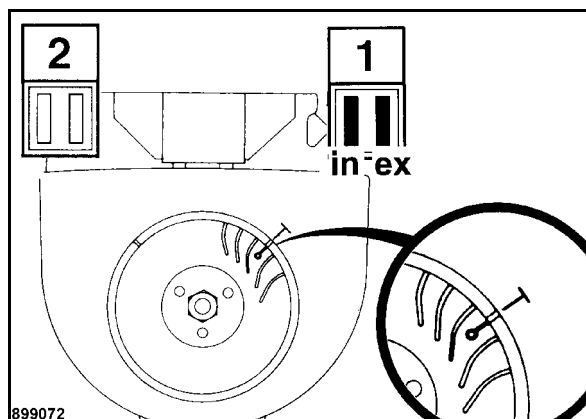

899072

Fig. 91

- Turn the flywheel with the cooling fan in clockwise direction (Fig. 91).

⚠ Caution

Do not turn by the fan blades.

- The T-marks on cooling fan and on the right hand side of the fan cover (cylinder 1) must be aligned.

i Note

The piston of cylinder 1 is in top dead center position.

The T-mark on the right hand side of the fan cover is only of relevance for cylinder 1.

- Check the valves marked black, adjust if necessary.

Every 500 operating hours

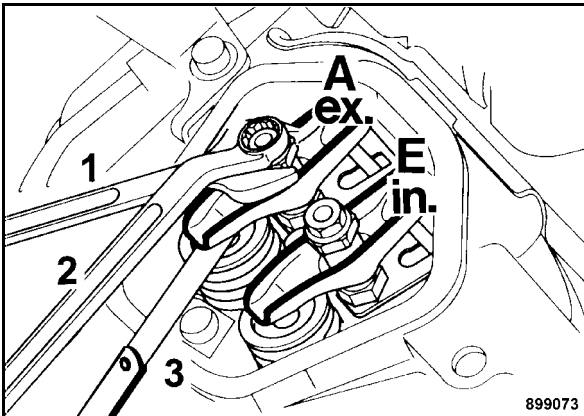

Fig. 92

Valve clearance

in. = intake valve 0.15 mm (.006 in)

ex. = exhaust valve 0.20 mm (.008 in)

- Check the gap between valve shaft and rocker arm with a feeler gauge 3 (Fig. 92).
- To adjust the valve clearance loosen the journal adjustment nut (2) and turn the rocker arm journal (1).
- After the adjustment tighten the journal adjustment nut with 9 Nm.

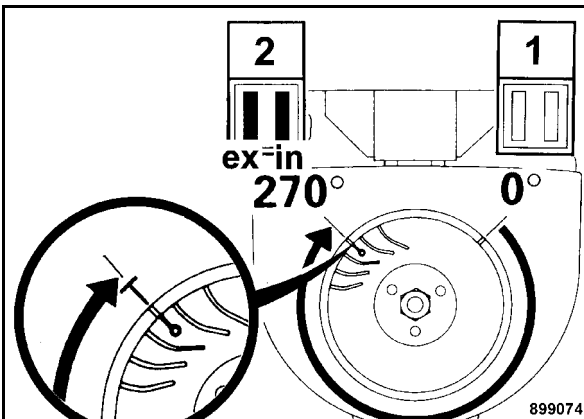

Fig. 93

- Turn the flywheel 270° in clockwise direction (Fig. 93).
- The T-marks on cooling fan and on the left hand side of the fan cover (cylinder 2) must be aligned.
- Check the valves marked black, adjust if necessary.

- After inspection and possible adjustment install the cylinder head covers with new gaskets.
- Tighten the cylinder head cover fastening screws with 9 Nm.

i Note

After a short test run check the engine for leaks.

5.22 Cleaning, changing the dry air filter

Caution

A dirty dry air filter cartridge can be noticed by excessive exhaust smoke.

A dry air filter cartridge with a damaged filter element or seal ring must be replaced in any case. It is therefore recommended to keep at least one cartridge in stock.

The dry air filter cartridge must be changed after 500 operating hours, but at the latest after 1 year.

Cleaning does not make sense if the air filter element is covered with a sooty deposit. Use a new filter cartridge.

Incorrectly handled filter cartridges may be ineffective if damaged (e.g. cracks) and cause damage to the engine.

Always replace the filter cartridge if it is soiled with wet or oily dirt.

Do not use gasoline or any hot fluids to clean the filter cartridge.

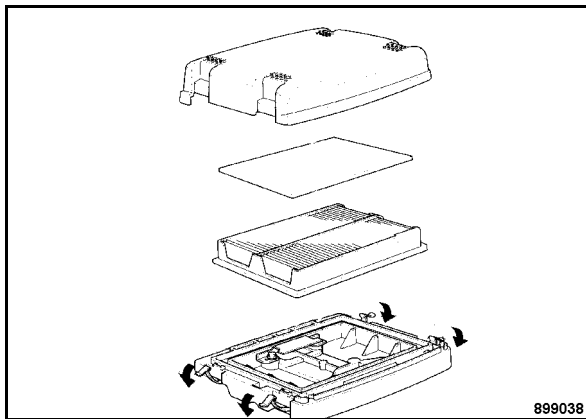
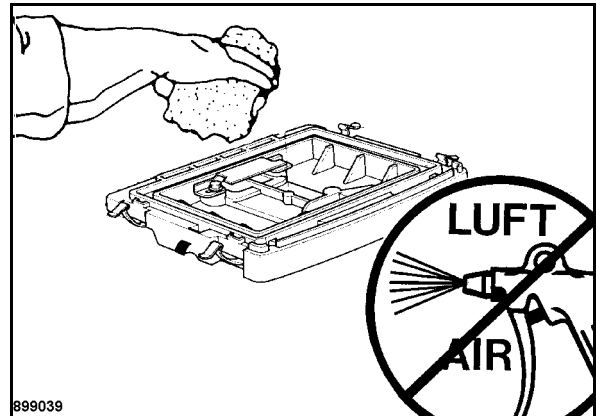

Fig. 94

- Remove the cover and take the air filter cartridge with foam insert (Fig. 94) out of the air filter housing cover.



899039

Fig. 95

- Clean the air filter housing with a clean cloth (Fig. 95).

Caution

Do not blow the filter housing out with compressed air.

- Replace a damaged dry air filter immediately.

Wet cleaning:

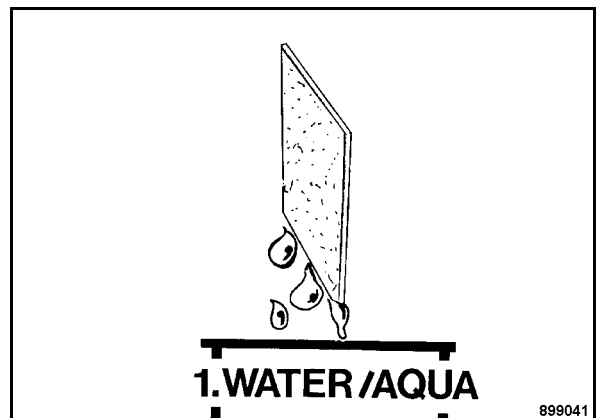

899041

Fig. 96

- Clean the foam filter by moving it to and fro in luke-warm water containing commercial detergent. Then rinse it thoroughly in clear water, shake all water off and let it dry properly (Fig. 96).

Caution

Do not use gasoline or any hot fluids to clean the filter cartridge.

- Before inserting the cartridge check the sealing faces on the dry air filter.

Every 500 operating hours

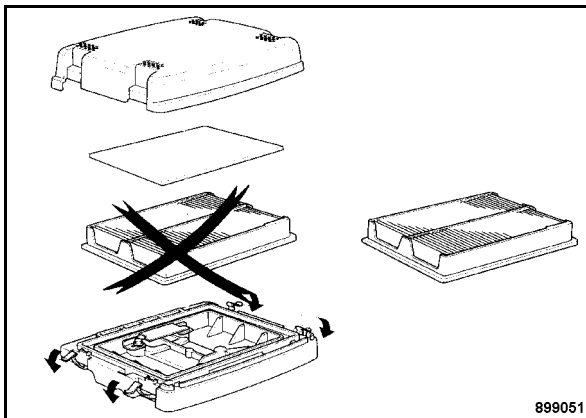

Fig. 97

- Lay the foam insert into the air filter cartridge into the air filter housing cover and then install the air filter cartridge (Fig. 97).
- Attach the air filter housing cover to the air filter housing and lock it with the hooks.

5.23 Changing the hydraulic oil

⚠ Danger

Danger of scalding!

Danger of scalding by hot hydraulic oil.

⚠ Caution

Do not start the engine after draining the hydraulic oil. Never run pumps without oil.

♻ Environment

Environmental damage

Catch and dispose of old oil environmentally.

i Note

Apart from the normal oil change intervals, the hydraulic oil must also be changed after major repairs in the hydraulic system.

Change the hydraulic oil filter with every hydraulic oil change (see next chapter).

See also chapter 5.1 "Notes on the hydraulic system".

- Drive the machine until the hydraulic oil has reached operating temperature.
- Clean the area around the fuel filler neck.
- Remove the filler cap.

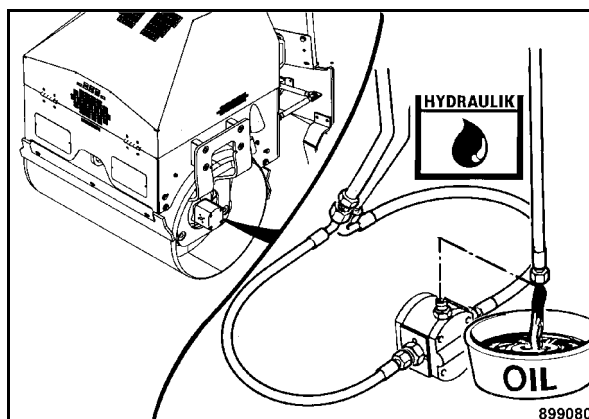

Fig. 98

- Unscrew the leak oil line from the vibration motor and catch the old oil (Fig. 98).
- Connect the leak oil hose again.

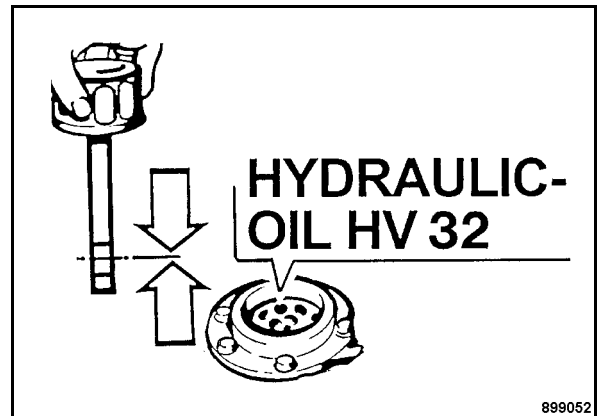

Fig. 99

i Note

We recommend to use a filtering unit with fine filter to fill in hydraulic oil.

For quality and quantity of oil refer to the table of "fuels and lubricants".

- Fill in new hydraulic oil (Fig. 99).
- Do not remove the screen filter during this process.
- Attach the filler cap.
- Check the hydraulic oil level on the dipstick.
- Perform a test run and check the system for leaks.

Bleeding the hydraulic system

- Run the engine max. 3 minutes with low speed, the hydraulic system will be bled during this time.

5.24 Changing the hydraulic oil filter element

⚠ Danger

Danger of scalding!

Danger of scalding by hot hydraulic oil.

⚠ Caution

Do not reuse the oil in the filter.

♻ Environment

Environmental damage

Catch running out oil and dispose of environmentally.

i Note

If the hydraulic oil filter contamination indicator on the filter shows "red" when the engine is running and at operating temperature, change the filter element.

With a clean oil filter the hydraulic oil filter contamination indicator will show "green".

The filter element must be changed with every hydraulic oil change and after major repairs in the hydraulic system.

If the filter has to be changed together with the hydraulic oil, the filter must only be changed after the oil change and after the test run.

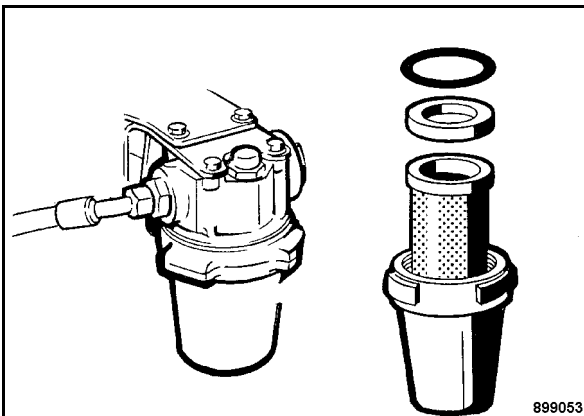

Fig. 100

- Unscrew the filter bowl (Fig. 100) from the filter housing.

- Take the old filter insert out and dispose of environmentally.
- Clean the filter bowl.
- Insert the filter element with the opening upwards and screw the filter bowl on, observe the condition of the seal ring.

5.25 Water sprinkler system, maintenance in the event of frost

Caution

In the event of frost the water sprinkler system must be drained or filled with an anti-freeze mixture respectively.

- Drain all water off.
- Switch the water sprinkler system on and let all remaining water run out.
- Fill the water tank with approx. 5 l of anti-freeze mixture (water and anti-freeze agent, e.g. glycol).
- Run the sprinkler system, until the anti-freeze mixture starts to run out from the sprinkler tubes.

5.26 Tightening torques for screws with metric unified thread

Bolt dimensions	Tightening torques* ft - lb		
	8.8	10.9	12.9
M4	2	3	4
M5	4	7	7
M6	7	11	13
M8	18	26	33
M10	37	55	61
M12	65	91	108
M14	101	145	173
M16	156	221	264
M18	213	303	361
M20	304	426	513
M22	413	559	695
M24	524	738	885
M27	774	1092	1308
M30	1047	1482	1770

Fig. 101

* Strength classes for screws with untreated, non-lubricated surface. The quality designation of the screws is stamped on the screw heads.

8.8 = 8G

10.9 = 10K

12.9 = 12K

The values result in a 90%ige utilization of the screws yield point, at a coefficient of friction of tot. = 0,14.

The compliance with the specified tightening torques is checked with torque wrenches.

The specified tightening torques do not apply when using a MoS₂ lubricant.

Note

Self locking nuts must always be replaced after they have been unscrewed.

5.27 Engine conservation

Caution

A machine with conserved engine must be clearly marked by attaching a clear warning label.

Note

Depending on weather conditions these conservation measures will protect the machine for approx. 6 to 12 months.

Before taking the machine back into service you must drain off the conservation oil and replace it with engine oil (see table of fuels and lubricants) according to API-(MIL-) classification.

Anti-corrosion oils are all oils which comply with the specification MIL-L-21260 B or TL 9150-037/2 o Nato Code C640/642.

If the engine is to be shut down for a longer period of time (e.g. over winter), we recommend the following measures to avoid corrosion:

- Clean engine and cooling system: With cold cleansing agent and water jet or, even better, with steam cleaning equipment.
- Run the engine warm and shut it down.
- Drain the still warm engine oil and fill in anti-corrosion engine oil.
- Drain the fuel from the fuel tank.
- Remove the cylinder head covers, spray the rocker chambers with anti-corrosion oil. Then fasten the covers again.
- Unscrew both spark plugs and spray anti-corrosion oil through the spark plug openings. Crank the engine several times and install the spark plugs again.
- Close air intake on air filter and exhaust opening tightly.

6 Troubleshooting

6.1 General notes

The following work must only be carried out by qualified and trained personnel or by the BOMAG sales service.

Please observe strictly the safety regulations in chapter 2 of these operating and maintenance instructions.

Malfunctions are frequently caused by incorrect operation of the machine or insufficient maintenance. Whenever a fault occurs you should therefore thoroughly read these instruction on correct operation and maintenance. If you cannot locate the cause of a fault or rectify it yourself by following the trouble shooting chart, you should contact the service departments at our branch offices or dealers.

On the following pages you will find a selection of fault remedies. It goes without saying that not all possible reasons for faults could be listed.

 Danger

Danger of injury!

Do not touch rotating parts of the engine.

6.2 Engine faults

Faults	Possible cause	Remedy
Engine not starting	<p>Fuel tank empty</p> <p>Fuel filter clogged</p> <p>Fuel lines leaking</p> <p>Travel lever not in 0-position</p> <p>Battery not charged or not connected</p> <p>Operating error</p> <p>Incorrect valve clearance</p> <p>Lack of oil</p>	<p>Fill fuel tank</p> <p>Change the filter</p> <p>Check the line connections for leaks and tighten the fittings.</p> <p>Return the travel lever to 0-position</p> <p>Charge battery, check terminal clamps</p> <p>see section 'Starting the engine'</p> <p>Adjust the valve clearance</p> <p>Fill up engine oil</p>
Poor starting of engine or engine works irregularly with poor power	<p>Insufficient battery power</p> <p>Terminal clamps loose or oxidized causing the starter to turn too slow</p> <p>Especially during winter: use of too viscous engine oil</p> <p>Insufficient fuel supply, fuel system clogged</p> <p>Valve clearance not as specified</p> <p>Carburettor defective</p> <p>Air filter dirty</p> <p>Excessive play in throttle cable</p>	<p>Have the battery checked</p> <p>Clean, tighten the terminal clamps and cover with acid-free grease</p> <p>Use engine oil appropriate for the outside temperature</p> <p>Change the fuel filter. Check the line connections for leaks and tighten the fittings.</p> <p>Adjust the valve clearance</p> <p>Have checked by a specialist</p> <p>clean, replace if necessary</p> <p>Adjust the throttle cable, replace if necessary</p>
Drop in engine power and speed, excessive exhaust smoke	<p>Engine oil level too high</p> <p>Poor fuel quality</p> <p>Air filter dirty</p> <p>Poor compression due to burned or broken piston rings or incorrect valve clearance</p>	<p>Drain the engine oil down to the top dipstick mark</p> <p>Use specified fuel</p> <p>clean, replace if necessary</p> <p>Have compression rings and pistons checked by a specialist, adjust the valve clearance</p>

Trouble shooting

Faults	Possible cause	Remedy
Engine over-heating, engine must be shut down immediately!	Cooling air inlets excessively soiled Engine oil level too low Lack of cooling air on cooling fan Air filter dirty	clean Fill up engine oil to the top dipstick mark Clear the cooling air duct clean, replace if necessary
Too low engine oil pressure, engine must be shut down immediately!	Leaks in the lubrication oil system, engine oil level too low Engine oil of wrong SAE-class	Check fittings on oil lines, lubrication oil filter for leaks, if necessary tighten all fittings. Fill up lubrication oil to the top mark on the oil dipstick. Change engine oil

We will help you - immediately!

Operating, maintenance, repair instructions and
spare parts catalogues



- in situ:

- Safe and simple trouble shooting
- Secure access to required spare parts
- Easy to understand – from experts for users

Contact us or your BOMAG distributor!

Head Office/Hauptsitz

BOMAG

Hellerwald
56154 Boppard
GERMANY
Tel.: +49 6742 100-0
Fax: +49 6742 3090
e-mail: germany@bomag.com
www.bomag.com



BOMAG

Niederlassung Berlin
Gewerbestraße 3
15366 Dahlewitz-Hoppegarten
GERMANY
Tel.: +49 3342 369410
Fax: +49 3342 369436
e-mail: nlberlin@bomag.de

BOMAG

Niederlassung Boppard
Hellerwald
56154 Boppard
GERMANY
Tel.: +49 6742 1000
Fax: +49 6742 100392
e-mail: nlboppard@bomag.de

BOMAG

Niederlassung Chemnitz
Querstraße 6
09247 Chemnitz
GERMANY
Tel.: +49 3722 51590
Fax: +49 3722 515951
e-mail: nlchemnitz@bomag.de

BOMAG

Niederlassung Hannover
Dieselstraße 44
30827 Garbsen-Berenbostel
GERMANY
Tel.: +49 5131 70060
Fax: +49 5131 6766
e-mail: nlhannover@bomag.de

BOMAG

Niederlassung München
Otto-Hahn-Ring 3
85301 Schweitenkirchen
GERMANY
Tel.: +49 8444 91840
Fax: +49 8444 918420
e-mail: nlmuenchen@bomag.de

BOMAG

Niederlassung Stuttgart
Uferstraße 22
73630 Remshalden-Grünbach
GERMANY
Tel.: +49 7151 986293
Fax: +49 7151 9862959
e-mail: nlstuttgart@bomag.de

BOMAG

Maschinenhandelsgesellschaft m.b.H.
Porschestraße 9
1230 Wien
AUSTRIA
Tel.: +43 1 69040-0
Fax: +43 1 69040-20
e-mail: austria@bomag.com

BOMAG (CANADA), INC.

1300 Aerowood Drive
Mississauga, Ontario L4W 1B7
CANADA
Tel.: +1 905 6256611
Fax: +1 905 6259570
e-mail: canada@bomag.com

BOMAG (China)

Compaction Machinery Co. Ltd.
No. 2808 West Huancheng Road
Shanghai Comprehensive Industrial
Zone (Fengxian)
Shanghai 201401
CHINA
Tel.: +86 21 33655566
Fax: +86 21 33655508
e-mail: china@bomag.com

BOMAG S.A.F.

2, avenue du Général de Gaulle
91170 Viry-Chatillon
FRANCE
Tel.: +33 1 69578600
Fax: +33 1 69962660
e-mail: france@bomag.com

BOMAG (GREAT BRITAIN), LTD.

Sheldon Way, Larkfield
Aylesford
Kent ME20 6SE
GREAT BRITAIN
Tel.: +44 1622 716611
Fax: +44 1622 718385
e-mail: gb@bomag.com

BOMAG Italia Srl.

Z.I. Via Mella, 6
25015 Desenzano del Garda (BS)
ITALY
Tel.: +39 030 9127263
Fax: +39 030 9127278
e-mail: italy@bomag.com

BOMAG Japan Co. Ltd.

Oval Court Ohsaki Mark
West Bldg. 8th floor
2-17-1, Higashi Gotanda
Shinagawa-ku, Tokyo
141-0022
JAPAN
Tel.: +81 3 5449 7560
Fax: +81 3 5449 0160
e-mail: japan@bomag.com

BOMAG

Representative Office Asia & Pacific
300 Beach Road
The Concourse, #38-03
Singapore 199555
SINGAPORE
Tel.: +65 294 1277
Fax: +65 294 1377
e-mail: singapore@bomag.com.sg

BOMAG Americas, Inc.

2000 Kentville Road
Kewanee, Illinois 61443
U.S.A.
Tel.: +1 309 8533571
Fax: +1 309 8520350
e-mail: usa@bomag.com

Printed in Germany